



60 Washington Ave, Suite 200
Bremerton, WA 98337
Ph: 360-824-4941

INVITATION FOR BIDS

M/V RELIANCE ENGINE REPLACEMENT AND REBUILD

IFB # KT 21-730

September 30, 2021

PROPOSALS DUE OCTOBER 19, 2021 NO LATER THAN 2:00 PM

Failure to include any of requested information and properly completed forms and documents may be cause for the rejection of the Bid.

Kitsap Transit, in accordance with Title VI of the Civil Rights Act of 1964, 78 Stat., 252, 42 U.S.C. 2000d to 2000-d4 and Title 49, Code of Federal Regulations, Department of Transportation, subtitle A, Office of the Secretary, Part 21, nondiscrimination in Federally-assisted programs of the Department of Transportation issued pursuant to such Act; hereby notifies all Bidders that it will affirmatively insure that in any Contract entered into pursuant to this advertisement, disadvantaged business enterprises as defined at 49 CFR Part 26 will be afforded full opportunity to submit Bids in response to this invitation and will not be discriminated against on the grounds of race, color, national origin, or sex in consideration for an Award.

Kitsap Transit reserves the right to reject any and all Proposals without cause and to waive any informalities or irregularities.

KITSAP TRANSIT REQUIREMENTS:

	Page
Section 1 Bid Advertisement	1
Section 2 Instructions for Bidders	3
Section 3 General Provisions	16
Section 4 Sample Contract	39
Section 5 Requests For Clarifications / Approved Alternates Form	54
Section 6 Bid Form	55

EXHIBITS:

- EXHIBIT A** Scope of Work and Specifications
- EXHIBIT B** Supplemental Bidder Responsibility Criteria Documentation Statements
- EXHIBIT C** Certification of Compliance with Wage Payment Statues

ATTACHMENTS:

- Attachment A** Reference Drawings

END OF TABLE OF CONTENTS

Advertisement Post Date: September 30, 2021

Kitsap Sun; Kitsap Transit Website: www.kitsaptransit.com; OMWBE;

INVITATION FOR BIDS

KT # 21-730 M/V RELIANCE ENGINE REPLACEMENT AND REBUILD

Scope of Work: The Work consists of removing two (2) each main engines in the port engine room and two (2) each main engines in the starboard engine room. Two (2) of the main engines will be replaced with Owner Furnished spares. The other two (2) engines will be replaced with existing after the completion of a major overhaul. Overhauls of existing engines (4 total) shall be completed by an OEM authorized service representative. The principal characteristics of the vessel are as follows:

- Length: 77'-3"
- Beam: 28'-0"

Bidding Documents: Plans, specifications and addenda for this project are available on-line through Kitsap Transit's Website www.kitsaptransit.com. Bidders must email Patrick Rogers at patrickr@kitsaptransit.com to be placed on the Plan Holder's List in order to receive automatic email notifications of future addenda and additional project information through the bid phase.

Pre-Bid Meeting: A non-mandatory Pre-Bid Meeting and ship check visit will be scheduled on October 6, 2021 at 10:00 AM. An explanation of the project and solicitation requirements will be provided with a question and answer session to follow. Following the project explanation, prospective Contractors will be allowed to tour the Work site.

Contractors should meet in Kitsap Transit's Administration building located at 60 Washington Ave Suite 200 Bremerton, WA 98337.

****As a reminder, Kitsap Transit follows the TSA guidelines around masks and social distancing. At this time, anyone on public transportation property must wear a face covering regardless of vaccination status.****

While attendance is not mandatory, Bidders are encouraged to attend. This meeting will provide prospective Bidders an opportunity to seek clarification and raise concerns related to the Solicitation. This meeting will also provide an opportunity to view current conditions at the location.

Pre-Bid Questions: All questions, requests for information, and Pre-Bid material substitutions, must be submitted in writing by **5:00 PM October 12, 2021** via e-mail: patrickr@kitsaptransit.com.

Plan Holder's List: Email Patrick Rogers at patrickr@kitsaptransit.com to have your firm added to the Plan Holder's List to automatically receive updates, addenda and other project information.

Time for Completion: The Contractor shall commence the Work under this Contract effective upon receipt of a written Notice to Proceed and shall continue in good faith and effort to Final Completion status within **sixty (60)** Calendar Days of said Notice.

Bid Due Date: Bids will be received at **Kitsap Transit's Reception Desk located in the Harborside Building 60 Washington Ave Suite 200 Bremerton WA 98337** until **2:00 PM on October 19, 2021**. When the official clock reads 2:00:01 PM, Bids are considered late and will not be considered for award. Immediately following the submission deadline, bids will be publically opened and read aloud in the Harborside Conference Room. Bids must be submitted on the forms provided.

Bid Security: Each bid must be accompanied by a Certified Check, Cashier's Check or Bid Security Bond made only on the Owner-provided form for a sum equal to 5% of the Total Bid Amount.

EQUAL OPPORTUNITY: It is Kitsap Transit's policy to ensure full compliance with Title VI of the Civil Rights Act of 1964 by prohibiting discrimination against any person on the basis of race, color, national origin or sex in the provision of benefits and services resulting from Federally assisted programs of the Department of Transportation and in the Award and administration of all Contracts. Small and women or minority owned Disadvantaged Business Enterprises (DBE), as defined in 49 CFR Part 26 are encouraged to submit Bids.

**END OF BID ADVERTISEMENT
(SECTION 1)**

2.1 Definitions:

Addenda: A written or graphic document, issued to all Bidders and identified as an Addendum prior to Bid opening, which modifies or supplements the Bid Documents and becomes a part of the Contract.

Bid/Proposal: The offer of a Bidder on a properly completed Bid Form to perform the Contract.

Bidder: means a person, firm or corporation that has made an offer in response to the IFB

Bid Documents: means the solicitation (IFB) in its entirety, including the Plans provided under separate cover

Contract: The written agreement between Kitsap Transit and the Contractor. The Contract includes, Contract Agreement, these solicitation documents, any and all Addenda issued, varies certifications and affidavits, supplemental agreements, change orders, and all Contractor.

Contractor: means the Successful Bidder who was awarded the Contract and has subsequently executed the Contract with Kitsap Transit.

IFB: is an abbreviation meaning Invitation for Bids.

Subcontractor: An individual, partnership, firm, corporation, or joint venture who is sublet part of the Contract by the Contractor.

Successful Bidder: means the lowest responsive and responsible Bidder to whom Award of the Contract shall be made

Surety: A company that is bound with the Contractor to ensure performance of the Contract, payment of all obligations pertaining to the Work, and fulfillment of such other conditions as are specified in the Contract as required by law.

Work: The provisions of all labor, materials, tolls, equipment and everything needed to successfully complete a project according to the Contract.

2.2 Anticipated Procurement Schedule: The activities and dates listed below represent the anticipated procurement schedule. Kitsap Transit will provide changes to the Pre-Bid date and Bid Due date via Addenda. Dates preceded by an asterisk (*) are estimated.

Activity	Date and Time
Invitation for Bids Released	September 30, 2021
Pre-Bid Meeting & Site Visit	10:00 AM at October 6, 2021
Request for Clarification/Substitutions Due	5:00 PM October 12, 2021
Bid Due Date	2:00 PM October 19, 2021
Board of Directors Award	November 2, 2021
Anticipated Notice to Proceed	*November 22, 2021

2.3 Examination of Bid Documents: Each Bidder shall thoroughly examine and be familiar with the Bid Documents. Submission of a Bid shall constitute an acknowledgment upon which Kitsap Transit may rely that the Bidder has thoroughly examined and is familiar with each part of the Bid Documents. The failure or neglect of a Bidder to receive or examine the Bid Documents, or any part thereof, shall in no way relieve it from the obligations with respect to its Bid or to the Contract. No claim for additional compensation shall be allowed based upon a lack of knowledge or

misunderstanding of this IFB, work sites, statutes, regulations, permits, ordinances, industry standards or resolutions.

2.4 Bid Forms: Kitsap Transit will accept only those Bids properly executed on the physical forms provided in this solicitation, unless Kitsap Transit states differently in writing. Bidders shall complete spaces on the Bid Form that calls for unit prices, extensions, the total Bid amount, signatures, date, acknowledgement of Addenda and the Bidder's address. The required certifications are included as part of the Bid Form.

2.5 Preparation of Bids: The resulting firm-fixed price Contract shall be Bid based on unit or lump pricing for each Bid Item listed on the Bid Schedule section of the Bid Form. Prices shall be stated in US currency, omitting digits more than two places to the right of the decimal point (i.e. \$720.74), and shall include everything necessary for the prosecution and completion of the Work as detailed in the Bid Documents.

All costs for insurance, bonds and prevailing wage filing fees shall be incidental to and included in the Bid Price and no additional payment will be made by Kitsap Transit, not even if the bond amount increases during the Contract Term.

All freight charges shall be included in the Bid price and should be (FOB) to the Awarded Vendors work site.

By submitting a Bid in response to this solicitation, Bidders agree to be bound by all legal requirements and Contract terms and conditions contained herein. Failure to include any of the requested information and properly completed forms and documents may be cause for immediate rejection of the Bid as non-responsive.

Bids shall remain valid for at least ninety (90) calendar days from the Bid Due Date. Kitsap Transit reserves the right to request extensions for Bid effectiveness. All Bids and submissions become the property of Kitsap Transit.

2.6 Bid Deposit: A deposit of at least 5% of the Bid shall accompany each Bid. This deposit may be certified check, cashier's check or a Bid Bond (Surety Bond) made on Kitsap Transit supplied form. A bid bond shall not be conditioned in any way to modify the minimum 5% required.

Any bid bond shall be on the form provided by Kitsap Transit and shall be signed by the Bidder and the Surety. The Surety shall:

- (1) Be registered with the Washington State Insurance Commissioners
- (2) Appear on the current Authorized Insurance List in the State of Washington published by the Office of the Insurance Commissioner

The failure to furnish a Bid deposit of a minimum of 5% with the Bid shall make the Bid nonresponsive and shall cause the Bid to be rejected by Kitsap Transit.

2.7 Delivery of Bids: By submitting a Bid in response to this solicitation, Bidders agree to be bound by all legal requirements and Contract terms and conditions contained herein. Failure to include any of the requested information and properly completed forms and documents may be cause for immediate rejection of the Bid as non-responsive.

Each Bid shall be sealed in an envelope and shall bear the name of the project as set forth in the IFB, the bid number, the name of the Bidder. Envelopes should be addressed to:

Kitsap Transit
Attn: Patrick Rogers

60 Washington Ave
Suite 200
Bremerton, WA 98337

Bids that are properly received will be publicly opened and read aloud. The Procurement Officer shall record all properly received bids and announce the apparent low bidder. Late Bids, electronic submissions (unless specifically stated), email or facsimile will be rejected.

- 2.8 State Sales Tax:** Kitsap Transit is subject to Washington State retail sales tax unless otherwise stated below. All invoices shall include a line item that clearly defines the retail sales tax to be paid by Kitsap Transit. Kitsap Transit will not adjust its payment if the Contractor bases a Bid on a misunderstanding of tax liability.

Kitsap Transit, at the request of the Washington State Department of Revenue, may deduct from its payments to the Contractor, retainage or lien the bonds, in the amount the Contractor owes the State, whether the amount owed relates to the Contract in question or not. Any amount so deducted will be paid into the proper State fund on the contractor's behalf.

The Washington State Department of Revenue has issued special rules on the state sales tax. When applicable, the following rules will apply:

2.8.1 State Sales Tax: WAC 458-20-171: (not applicable)

2.8.2 Service (not applicable)

2.8.3 RCW 82.08.0285 Ferry Vessels: provides for a retail sales tax exemption on labor and materials that "becomes a component part" of a ferry vessel. The Awarded Vendor will receive a signed DOR Buyer's Retail Sales Tax Exemption Certificate at the time of Contract signing.

- 2.9 Bid Evaluation:** Bids will be evaluated on the Total Bid Amount before applicable Sales Tax. Full responsive and responsibility reviews will be conducted after Bid Opening, therefore the apparent low Bidder at the time of Bid Opening may not necessarily be recommended for Contract Award if they are determined to be non-responsive or their Bid is disqualified as being non-responsive. Kitsap Transit reserves the right to request additional information from Bidders to further determine responsibility or to clarify items in a Bid.

Kitsap Transit reserves the right to reject irregular Bids. Bids are considered irregular when: Bid forms are not properly executed, Bidder fails to return all of the required forms, Bidder does not include a unit price for every Bid item, any of the unit prices are excessively unbalanced (either above or below the amount of a reasonable Bid) to the potential detriment of Kitsap Transit, the Bid is conditioned in any way, entries are illegible, or the Bid contains unauthorized additions, deletions, alternate Bids or conditions.

Kitsap Transit's determination to reject a Bid is final.

- 2.10 Identical Bid Totals:** If two or more lowest responsive Bids are exactly equal, the tie-breaker will be determined with a draw. Only those Bidders who submitted a Bid total that is exactly equal to the lowest responsive Bid are eligible to participate. Two or more slips of paper will be marked with the names of the tied firms, folded, placed inside a box and shook up. One authorized representative of Kitsap Transit shall draw one slip from the box and announce the name of the successful Bidder.
- 2.11 One Bid Received Procedure:** If only a single responsive and responsible Bid is received, Kitsap Transit shall have the right, in its sole discretion, to extend the Bid Due Date for up to an additional

sixty (60) days and/or to conduct a price or cost analysis on such single Bid. The single Bidder shall promptly provide all cost and pricing data, documentation and explanation requested by Kitsap Transit to assist in such analysis. By conducting such analysis, Kitsap Transit shall not be obligated to accept the single Bid and reserves the right to reject such Bid or any portion thereof.

- 2.12 Non-Submittal:** Kitsap Transit would appreciate any potential Bidder determining not to submit a Bid response to this solicitation, to complete and return the “*No Bid Notice*”, Section 6. Please state the reason(s) why a Bid could not be submitted at this time.
- 2.13 Bid Modifications:** Bidders will not be allowed to alter Bids after the Bid submittal deadline. Submitted Bids may only be changed if a written request is received by Kitsap Transit *before* the Bid submittal deadline. Such requests must be signed by an individual authorized to submit Bids on behalf of the company. All modifications shall be made in writing, executed and submitted in the same form and manner as the original Bid. Nothing in this section shall be construed to permit the Bidder to alter its Bid after it has been submitted pursuant to the terms of this solicitation.
- 2.14 Bid Withdrawal:** No Bidder may withdraw their Bid after the Bid submittal deadline unless Contract Award is delayed for a period exceeding sixty (90) calendar days following Bid Opening. Any Bid not so timely withdrawn shall constitute an irrevocable offer for a period of sixty (90) days to provide Kitsap Transit the goods and services described herein, or until one or more of the Bids have been approved by Kitsap Transit, whichever occurs first.
- 2.15 Bid Extension or Cancellation:** Kitsap Transit reserves the right to cancel this solicitation, or extend the Bid submittal deadline or Bid Opening, by written Addendum, at any time *before* the specified deadline, or in the event only a single Bid or no Bids are received. If a Bidder pursues a protest or a request for reconsideration, its Bid is deemed extended until Kitsap Transit executes the Contract or until the protest or request for reconsideration is withdrawn by the Bidder.
- 2.16 Errors and Administrative Corrections:** Kitsap Transit will not be responsible for any errors in Bids. Kitsap Transit reserves the right to make mathematical corrections that are due to administrative or clerical typing errors, number transposition and incorrect calculations. Kitsap Transit may waive these irregularities as immaterial. In the event of a discrepancy between the unit price and the extended amount, the unit price will govern. If figures are set forth in both words and numbers and there is a disparity, the words will take precedence over its numerical counterpart.
- 2.17 Collusion:** By signing a Bid, the Bidder certifies that its Bid is non-collusive and not made in the interest of any person not named, and that the Bidder has not induced or solicited others to submit a sham offer, or to refrain from proposing. If Kitsap Transit determines that collusion has occurred among Bidders, none of the Bids of the participants in such collusion will be considered. Kitsap Transit’s determination shall be final.
- 2.18 Rejection and Consideration of Bids:** Kitsap Transit, in its sole discretion, reserves the right to: Accept or reject any or all Bids, portions or parts thereof; Waive minor Bid errors, informalities, or immaterial irregularities when it is in Kitsap Transit’s best interest and does not result in displacement of a low Bidder; Republish the call for Bids; Revise or cancel the Work or require the Work to be done in another way; Decline award based on available funding for the Contract; and Award in whole or in part to the lowest responsive and responsible Bidder as best serves the interest of Kitsap Transit. In consideration for Kitsap Transit’s review and evaluation of its Bid, the Bidder waives and releases any claims against Kitsap Transit arising from any rejection of any or all Bids, including any claim for costs incurred by Bidders in the preparation of Bids submitted in response to this solicitation.
- 2.19 Disadvantaged Business Enterprise Goal:** The purpose of the Disadvantaged Business Enterprise (DBE) overall goal is to achieve a “level playing field” for ready, willing and able DBE’s

seeking to participate in Federally-assisted Contracts. Kitsap Transit's DBE goal for Federal fiscal year 2021 is 2.92%, the full text of which may be found at:

<http://www.kitsaptransit.com/uploads/pdf/projects/ktdbeprogram.pdf>.

- 2.20 Fostering Small Business:** KT takes reasonable steps to facilitate fair competition by incorporating small business concerns into its Federal procurement practices. As part of this effort, KT actively seeks Bids from qualified small businesses, including DBEs. KT also encourages Prime Contractors to provide subcontracting opportunities of a size and nature that small businesses can reasonably compete and perform effectively.
- 2.21 Title VI:** It is the policy of KT to assure that no person shall, on the grounds of race, color, national origin or sex, as provided by Title VI of the Civil Rights Act of 1964, be excluded from participation in, be denied the benefits of, or otherwise be discriminated against under any of its federally funded programs and activities. The full text of KT's Title VI program is available online at [http://www.kitsaptransit.com/static/62/privacy-policy#title vi](http://www.kitsaptransit.com/static/62/privacy-policy#title_vi).
- 2.22 Brand Names:** The use of any brand names, manufacturer, make or catalog number does not restrict the Bidder. Such use is to identify the standards of desired characteristics, quality and performance equivalence of the product on which Bids are submitted. Kitsap Transit reserves the right to decide whether or not proposed alternates are equivalent to the product described in the solicitation, of which decision shall be final. Any substitutions must, without exception, be manufactured of the same basic materials, meet or exceed all Specification requirements of structural, functional, dimensional and appearance without deviation. Kitsap Transit reserves the right to reject any and all substitutions.
- 2.23 Bidder Claiming Error Procedure:** If a Bidder realizes after Bid Opening that it has made a clerical, administrative or judgment error and wants to be relieved of its Bid obligations, the Bidder must notify Kitsap Transit in writing before 5:00 p.m. on the first business day after Bid Opening. The Bidder shall submit a notarized affidavit, or declaration under penalty of perjury, which is signed by the Bidder and includes a description of the nature of the error, a request to be relieved from the responsibilities of Award, and is accompanied by the Bidder's original worksheets used in preparing the Bid which demonstrate the error. If Kitsap Transit determines the error allows relief from forfeiture of the Bid Bond, the Bidder will be relieved of any further responsibility and the Bid Bond will be returned. If Kitsap Transit determines the error does not lawfully allow relief, then Award may proceed and if the Bidder refuses to execute the Contract, the Bidder's Bid Bond shall be forfeited. Per RCW 39.04.107, the low Bidder claiming error will be prohibited from Bidding on the same project if a second or subsequent call for Bids is made for the project. Kitsap Transit reserves the right to request any Bidder to withdraw an unbalanced Bid.
- 2.24 Bidder Responsibility Criteria (Mandatory):**
- A) It is the intent of Kitsap Transit to Award the Contract to the low responsive and responsible Bidder. Before Award, the Bidder must meet the following mandatory Bidder responsibility criteria stated in RCW 39.04.350(1) to be considered a responsible Bidder qualified to be awarded a Public Works Contract in Washington State. Failure of any Bidder to meet the responsibility criteria will automatically deem the Bidder not responsible and be just cause for rejection of the Bid.
 - B) As assurance to Kitsap Transit that the Bidder meets the criteria, Bidders must provide this information, as applicable, directly on the spaces provided on the Bid Form. Kitsap Transit may require additional documentation from the Bidder demonstrating compliance with the criteria. Failure of a Bidder to respond to such a request for additional information or clarification may result in rejection of its Bid. Bidder must:

- 1) Have a current certificate of registration as a Contractor in compliance with Chapter 18.27 RCW, which must be in effect at the time of Bid submittal;
- 2) Have a current Washington Unified Business Identifier (UBI) number;
- 3) If applicable:
 - (a) Have Industrial Insurance (Worker's Compensation) coverage for all of the Bidder's employees working in Washington, as required in Title 51 RCW;
 - (b) Have a Washington Employment Security Dept. number, as required in Title 50 RCW;
 - (c) Have a Washington Department of Revenue state excise tax registration number, as required in Title 82 RCW.
- 4) Not be disqualified from Bidding on any Public Works Contract under RCW 39.06.010 or 39.12.065(3).
- 5) Have received training of the requirements related to public works and prevailing wage under this chapter (39.04.350) and chapter 39.12 RCW. The training must be provided by the department of labor and industries or by a training provider whose curriculum is approved by the department. Bidders that have completed three or more public works projects and have had a valid business license in Washington for three or more years are exempt from the training requirement.
- 6) Bidders must certify that they are not a willful violator of the States' wage payment statutes (**Exhibit C**).

2.25 Supplemental Bidder Responsibility Criteria:

As evidence that the Bidder meets the mandatory and Supplemental Responsibility Criteria, **Bidders must submit with their Bid**, written verification that the Bidder meets all of the mandatory and supplemental criteria together with supporting documentation, including but not limited to that detailed below which, in the sole judgment of Kitsap Transit, demonstrates compliance with all mandatory and Supplemental Responsibility Criteria. Kitsap Transit reserves the right to request such documentation from other Bidders also. Complete the Documentation Statements provided in **Exhibit B**. Number all supporting documentation according to this section layout.

A) Delinquent State Taxes

- 1) **Criterion:** The Bidder shall not owe delinquent taxes to the Washington State Department of Revenue without a payment plan approved by the Department of Revenue.
- 2) **Documentation:** The Bidder shall not be listed on the Washington State Department of Revenue's "Delinquent Taxpayer List" website (for Bidder assistance, the website is currently: <http://dor.wa.gov/content/fileandpaytaxes/latefiling/dtlwest.aspx>), unless accompanied by a written payment plan approved by the Department of Revenue.

B) Reserved

C) Claims Against Retainage and Bonds

- 1) **Criterion:** The Bidder shall not have a record of excessive claims filed against the retainage or payment bonds for Public Works projects during the previous three (3) years that demonstrate a lack of effective management by the Bidder of making timely and appropriate payments to its Subcontractors, suppliers, and workers, unless there are extenuating circumstances acceptable to Kitsap Transit in its sole discretion.
- 2) **Documentation:** The Bidder shall submit a list of the Public Works projects completed within the previous three (3) years and include for each project the following information:

- Name of project;
- The owner and contact information for the owner;
- A list of claims filed against the retainage and/or payment bond for any of the projects listed; and
- A written explanation of the circumstances surrounding each claim and the ultimate resolution of the claim.

Kitsap Transit reserves the right to contact other owners to validate the information provided by the Bidder and to conduct its own investigation into claims against the Bidder's retainage and payment bonds.

D) Subcontractor Responsibility

- 1) **Criterion:** The Bidder's standard subcontract form shall include the Subcontractor responsibility language required by RCW 39.06.020 and the Bidder shall have an established procedure which it utilizes to validate the responsibility of each Subcontractor. The Bidder's subcontract form shall also include a requirement that each of its Subcontractors shall have a document of similar procedure to determine whether the sub-tier Subcontractors with whom it contracts are also "responsible" Subcontractors as defined by RCW 39.06.020.
- 2) **Documentation:** The Bidder shall submit a copy of its standard subcontract form for review by Kitsap Transit and a written description of its procedure for validating the responsibility of Subcontractors with which it contracts.

E) Public Bidding Crime

- 1) **Criterion:** The Bidder and its owners shall not have been convicted of a crime involving Bidding on a Public Works Contract within five (5) years from the Bid submittal deadline for this project.
- 2) **Documentation:** The Bidder shall sign a Kitsap Transit provided statement providing that the Bidder and its owners have not been convicted of a crime involving Bidding on a Public Works Contract within the aforementioned time period. If the Bidder has been convicted of such crime within this time frame, the Bidder will provide Kitsap Transit a list showing the date of conviction, the offense convicted of, the punishment, and a brief statement of the facts underlying the condition. Kitsap Transit reserves the right to use independent sources of information to demonstrate whether the Bidder is in compliance with this criterion.

F) Termination for Cause / Termination for Default

- 1) **Criterion:** The Bidder shall not have had any Public Works Contract terminated for cause or terminated for default by a government agency during the five (5) year period immediately preceding the Bid submittal deadline for this project, unless there are extenuating circumstances acceptable to Kitsap Transit in its sole discretion.
- 2) **Documentation:** The Bidder shall sign a Kitsap Transit provided statement providing that the Bidder has not had any Public Works Contract terminated for cause or default by a government agency within the aforementioned time period. If the Bidder has had a Public Works Contract terminated for cause or default by a government agency during this time frame, the Bidder will provide Kitsap Transit a list of each Contract terminated, the government agency terminating the Contract, and the circumstances involving the termination. Kitsap Transit reserves the right to use independent sources of information that may be available to demonstrate whether the Bidder complies with this criterion.

G) Lawsuits

- 1) **Criterion:** The Bidder shall not have lawsuits (or arbitrations for those instances where arbitration is completed in lieu of a lawsuit) with judgments entered against the Bidder within five (5) years of the Bid submittal deadline for this project that demonstrates a pattern of failing to meet the terms of Contracts, unless there are extenuating circumstances acceptable to Kitsap Transit in its sole discretion.
 - 2) **Documentation:** The Bidder shall submit a list of lawsuits or arbitrations with judgments entered against the Bidder within the aforementioned time period, along with a written explanation of the circumstances surrounding each such lawsuit or arbitration. Kitsap Transit shall evaluate these explanations to determine whether the lawsuits or arbitrations demonstrate a pattern of failing to meet terms in Contracts. Kitsap Transit reserves the right to investigate and evaluate lawsuits or arbitrations made against the Bidder within the time period specified that were not reported by the Bidder.
- H) **Appeals:** If Kitsap Transit determines the Bidder does not meet the Bidder responsibility criteria outlined herein and is therefore not a responsible Bidder, Kitsap Transit shall notify the Bidder in writing with the reasons for its determination. If the Bidder disagrees with Kitsap Transit's determination, the Bidder will have one (1) business day from receiving the determination to appeal and present additional information to Kitsap Transit. Kitsap Transit will consider any such timely submitted additional information before issuing its final determination. If the Bidder disagrees with Kitsap Transit's final determination, it may appeal that determination to the Board Chair of the Kitsap Transit Board of Directors within one (1) business day of receiving Kitsap Transit's final determination. If the Board of Directors affirms that the Bidder is not responsible, Kitsap Transit will not execute a Contract with any other Bidder until two (2) business days after the Bidder determined to be not responsible has received the final determination.
- I) **Request to Change Supplemental Criteria during Bidding**
- 1) Potential Bidders with concerns about the relevancy or restrictiveness of the Supplemental Bidder Responsibility Criteria may make or submit requests ("Request") to Kitsap Transit to modify the criteria. Such requests shall be made in writing, describe the nature of the concern(s), and propose specific modifications to the criteria that will make the criteria more relevant and/or less restrictive of competition. Bidders should submit such requests no later than five (5) business days prior to Bid Opening. Requests may be submitted via U.S. post mail, hand-delivered, or sent by electronic mail within this timeline to:
 - Mail/Delivery: Patrick Rogers
Kitsap Transit
60 Washington Ave., Ste. 200
Bremerton, WA 98337-1888
 - E-mail: patrickr@kitsaptransit.com
 - 2) The Request must include the Bidder's name and address, the Project Number and Title, the applicable criteria the Bidder is seeking to modify, the justification for why the identified criteria should be modified, and how the Requestor would like the criteria modified. Requests either not addressed to the Contracts Administrator as indicated in Item 1 above, or requests received after the request submittal deadline, will not be considered.
 - 3) Any changes to the Supplemental Bidder Criteria, as determined by Kitsap Transit in its sole discretion, will be issued as an Addendum to the Bid Documents.

2.26 Award of Contract: Only one Bidder will be selected for Contract Award. An Award Recommendation Notice, setting forth Kitsap Transit's intent to recommend Contract Award to the lowest responsive and responsible Bidder, will be sent to all Bidders. The recommendation will be

voted upon by the Kitsap Transit Board of Directors in open public meeting on the date specified within the Notice. Upon receiving Board approval for Award of the Contract, Kitsap Transit will send a Final Notice of Contract Award to all Bidders. Kitsap Transit reserves the right to make Award within ninety (90) calendar days from the Bid Due Date. Should Award, in whole or part, be delayed beyond the period of ninety (90) days, such Award shall be conditioned upon Bidder's acceptance.

2.27 Contract Execution: The Contractor must sign and return all requested documents to Kitsap Transit within ten (10) calendar days of the Award Date. After execution, one (1) original signed Contract will be returned to Kitsap Transit with all requested documents. The Bidder should already have preparations in place with their insurance agent and Surety in order to expedite the required documents. Failure to execute the Contract is the time allotted grants the authority to cancel the Award and move to the next lowest responsive and responsible Bidder.

Kitsap Transit will then issue a Notice to Proceed. The Contractor assumes all risk for any Work begun before receipt of the said notice.

2.28 Bids as Public Record: Except to the extent permitted by Washington State public disclosure laws RCW Chapter 42.56, Kitsap Transit will regard Bids as public records which will be available for public inspection and/or copying following Contract Award, regardless of any markings or notices contained in the Proposal documents. Information will not be released by Kitsap Transit prior to Contract Award in order to protect the integrity of the procurement process, unless otherwise required by law. All Bids will remain confidential until a Contract is awarded and fully executed by all parties involved. If a Bidder considers portions of its Bid to be protected under Washington State law, the Bidder shall clearly identify and mark such portions as "CONFIDENTIAL" or "PROPRIETARY" and submit such portions in a sealed envelope, separate from the rest of the Bid. It is not usually reasonable or legally defensible to mark an entire Bid as "confidential" or "proprietary". Marking the entire Bid as such will not be honored and the Bid may be rejected as non-responsive. Kitsap Transit shall make Bid submittal details available to the public after Contract Award except, to the extent consistent with RCW 42.56 those portions marked "Confidential" according to the above requirement. If a member of the public demands to review portions of a Bid marked "Confidential", Kitsap Transit will notify the affected Bidder prior to releasing such portions. The Bidder shall take such legal action as it may determine to be necessary to protect its interest. If the Bidder has not commenced such action within five (5) calendar days after receipt of the notice, Kitsap Transit will make the requested portions available for review and copying by the public. The Bidder asserting that portions of its Bid are legally protected shall bear all costs of defending such assertion, including reimbursing Kitsap Transit for its administrative, expert and legal costs involved in defending itself in actions arising from such assertions by the Bidder. Kitsap Transit assumes no responsibility or liability for any losses or damages which may result from the information contained in the Bid. By submitting a Bid, the Bidder has thereby agreed to the provision of this sub-section.

2.29 Bid Protests:

Who May Protest or Appeal

A potential bidder demonstrating a substantial economic interest in Kitsap Transit's competitive bid process.

Timing of Protest

A protest must be filed within five business days of the award of a contract or notice of apparent successful proposer/bidder, whichever is sooner.

Basis of Protest

Protests must be based on the following criteria:

1. A matter of bias, discrimination, or conflict of interest

2. Non-compliance with procedures described in the procurement documents
3. Error in computing scores

Protest Form and Content

1. Protests must be in writing
2. Protests must be addressed to the Purchasing Coordinator
3. Protests must clearly articulate specific grounds for the protest and include supporting documentation
4. Protests must include proposed remedy

Protest Procedure

A protest must be filed with Kitsap Transit's Purchasing Coordinator within five business days of the award of a contract or notice of apparent successful proposer/bidder, whichever is sooner. Upon receipt of a timely written protest, the Purchasing Coordinator will consider the protest in accordance with established procedures and issue a written decision within five business days stating the reasons for the action taken and informing the allegedly aggrieved vendor or service provider (Protesting Vendor) of his/her right to appeal the decision.

Appeal Procedure

An appeal must be filed within five business days of the Purchasing Coordinator decision. The Finance Director and an independent Department Director will consider the appeal and issue a written decision within five business days informing the Protesting Vendor of his/her right to further appeal the decision.

In the event the Protesting Vendor elects to continue the appeal process, a request for a second appeal must be filed within five business days of the decision of the first appeal. The Executive Director will consider the appeal and issue a written decision within ten business days. The decision of the second appeal will be final and conclusive.

Failure to Comply with Requirements

Failure to comply with the protest and appeal requirements will render a protest or an appeal untimely or inadequate and may result in rejection thereof.

Protests to the Federal Transit Administration

The vendor or service provider shall only appeal to the FTA pursuant to violations of federal law or regulation.

Exhausted Administrative Remedies

A Protesting Vendor may not commence litigation prior to exhausting all administrative remedies. Failure to exhaust all administrative remedies shall constitute an absolute waiver of the Protesting Vendor rights, if any, to commence litigation.

Failure of the Protestor to submit a written Notice of Protest in accordance with the specified timelines contained herein shall constitute a waiver of all right to protest.

2.30 Environmental Sustainability Management System Compliance: (not applicable)

2.31 Insurance Requirements: The Contractor shall, at its sole cost and expense, obtain and maintain during the entire term of this Contract the minimum insurance set forth below. In the event the Contractor is a Joint Venture, these insurance requirements shall apply to each Joint Venture member separately. By requiring such minimum insurance, Kitsap Transit shall not be deemed or construed to have assessed the risks that may be applicable to the Contractor under this Contract. The Contractor shall assess its own risks and, if it deems appropriate and/or prudent, maintain greater limits and/or broader coverage. The fact that insurance is obtained by Contractor shall not be deemed to release or diminish the liability of Contractor, including without limitation, liability

under the indemnity provisions of this Contract. Damages recoverable by Kitsap Transit shall not be limited to the amount of the required insurance coverage.

- a. **General Liability:** Commercial General Liability for bodily injury including death, personal injury and property damage coverage, with contractual and completed operations endorsements, utilizing insurers and coverage forms acceptable to Kitsap Transit, with a limit of at least \$1,000,000 per occurrence, \$2,000,000 general aggregate and \$2,000,000 products completed operations aggregate limit.
- b. **Automobile Liability:** Commercial Auto Liability coverage for bodily injury and property damage utilizing insurers and coverage forms acceptable to Kitsap Transit, with a limit of at least \$1,000,000 per accident.
- c. **Ship Repairer's Liability:** Coverage usual to American Institute Ship Repairer's Liability Clauses with a limit of \$1,000,000. Demurrage/Detention coverage added. This coverage may be added to the General Liability Policy.
- d. **Workers Compensation:** The Contractor and Subcontractor will secure in accordance with the laws of the State(s) of operation, Coverage B-Employers' Liability Limit \$1,000,000 each accident. U.S. Longshore and Harbor Workers **{USL&H}** Compensation Act coverage. The Contractor and Subcontractor will be responsible for Workers Compensation insurance for any Subcontractor who provides services under subcontract. If the Contractor and Subcontractor are qualified as a self-insurer under Chapter 51.14 of the Revised Code of Washington, it will so certify to the Owner by submitting a letter signed by a corporate officer, indicating that it is a qualified self-insurer, and setting forth the limits of any policy of excess insurance covering its employees/s.
- e. **Builder's Risk Policy:** Coverage usual to American Institute Builder's Risk Clauses {2-8-79} including American Hull Insurance Syndicate Addenda 1 & 2, including coverage for Strikes, Riots, and Civil Commotion and vandalism. Coverage for Owner Furnished Equipment, if any, while in transit and in storage awaiting installation. Coverage for Protection & Indemnity and Pollution Liability. The Protection and Indemnity section of the Builder's Risk Insurance Policy for the Builders shall be amended to provide Jones Act Crew Coverage for employees of Purchaser. Limit for Hull & Machinery to be the completed value of the Vessel including Owner Furnished Equipment or the cost to rebuild the Vessel following a total loss, whichever is greater. Limit for Protection & Indemnity to be not less than \$1,000,000 or the completed value of the Vessel, whichever is greater (unless excess limit is included in a Bumbershoot Policy).
- f. **Certificates and Policies:** Prior to commencement of services for this Contract, the Contractor shall provide Kitsap Transit with certificates of insurance showing insurance coverage in compliance with the above Paragraphs. All insurance coverage outlined above shall be written by insurance companies meeting Kitsap Transit's financial security requirements, (A.M. Best's Key Rating A-; VII or higher). **Such certificates shall reference the title of this Contract** and will state that the Contractor shall provide thirty (30) calendar days advance written notice to Kitsap Transit in the event the Contractor's insurance policies are cancelled, not renewed, or materially reduced in coverage. Should the Contractor neglect to obtain and maintain in force any of the insurance required in this Section, Kitsap Transit may suspend or terminate this Contract.

Suspension or termination of this Contract shall not relieve the Contractor from insurance obligations hereunder.

- g. General Terms of Insurance:** All policies shall contain a waiver of subrogation in favor of KITSAP TRANSIT. All policies (except Workers Compensation/ USL&H, Ship Repairer's Liability, and Auto Liability) shall name KITSAP TRANSIT as Additional Insured. Language such as the following should be used: "**Kitsap Transit and its officers, agents, and employees named Additional Insured in respect to Contract KT 21-730 M/V Reliance Engine Replacement and Rebuild**". All policies (except Workers Compensation/ USL&H, Ship Repairer's Liability, and Auto Liability) shall be endorsed to be primary to any similar coverage available to KITSAP TRANSIT.
- h. Certificates and Policies:** Prior to commencement of services for this Contract, the Contractor shall provide Kitsap Transit with certificates of insurance showing insurance coverage in compliance with the above Paragraphs. All insurance coverage outlined above shall be written by insurance companies meeting Kitsap Transit's financial security requirements, (A.M. Best's Key Rating A-; VII or higher). Such certificates shall reference the title of this Contract and will state that the Contractor shall provide thirty (30) calendar days advance written notice to Kitsap Transit in the event the Contractor's insurance policies are cancelled, not renewed, or materially reduced in coverage. Should the Contractor neglect to obtain and maintain in force any of the insurance required in this Section, Kitsap Transit may suspend or terminate this Contract. Suspension or termination of this Contract shall not relieve the Contractor from insurance obligations hereunder.

Taking into account the Scope of Work and Services to be performed by a Subcontractor, the Contractor shall prudently determine whether, and in what amounts, each Subcontractor shall obtain and maintain public liability, professional liability, and any other insurance coverage. Any insurance required of Subcontractors shall, where appropriate and/or applicable, name Kitsap Transit as an additional insured.

The Contractor and its insurers shall endorse the required insurance policy (ies) to waive their right of subrogation against Kitsap Transit. The Contractor and its insurers also waive their right of subrogation against Kitsap Transit for loss of its owned or leased property or property under its care, custody and control.

No provision in this Section shall be construed to limit the liability of the Contractor for services not done in accordance with the Contract, or express or implied warranties. The Contractor's liability for the services shall extend as far as the appropriate periods of limitation provided by law and up to any legal limits.

The Contractor may obtain any combination of coverage or limits that effectively provides the same or better amounts and types of coverage as stipulated above, subject to review and approval by Kitsap Transit.

The Contractor warrants that this Contract has been thoroughly reviewed by the Contractor's insurance agent(s)/broker(s), who have been instructed by Contractor to procure the insurance coverage required by this Contract.

Failure of the Protestor to submit a written Notice of Protest in accordance with the specified timelines contained herein shall constitute a waiver of all right to protest.

END OF SECTION 2

The following Kitsap Transit General Provisions are complementary to the Special Provisions and to the terms and conditions of the subsequent Contract to be executed between the Parties. Any provision of law, rule, or regulation that is required to be included in this Contract will be read as if in this Contract whether or not physically included.

3.1 CONTRACT DOCUMENTS

- A) The Contract Documents are intended to be complementary and prescribe and provide for a complete Work. The Contractor shall furnish all labor, materials, tools, equipment, transportation, supplies, and incidentals required to complete all Work for the items included in the Bid Schedule. Compensation for the cost of furnishing the foregoing and for full performance of the Work in full conformance with the Contract Documents is included in the Contract Amount.
- B) The Contract represents the entire and integrated agreement between Kitsap Transit and the Contractor and sets forth the rights and responsibilities of the parties in accordance with the laws of the State of Washington. Each Contract Document is an essential part of the Contract and a requirement present in one Contract Document is binding as though it was present in all. Anything mentioned in the Specifications and not shown in the Plans, or shown in the Plans and not mentioned in the Specifications, shall be of like effect as shown or mentioned in both. Any Work, materials or equipment that has not been specifically included in the Contract Documents but which is reasonably required to produce the intended result shall be provided by the Contractor as though it had been specifically included.
- C) Plan Drawings indicate only such details as are necessary to give a comprehensive idea of the Work. The Project Manager, or Engineer, may furnish the Contractor with such additional drawings and clarifications, consistent with the purpose and intent of the Contract Documents, as deemed necessary to detail and illustrate such Work. The Contractor shall conform its Work to such drawings and explanations. The furnishing of such additional drawings or clarifications shall not entitle the Contractor to an increase in the Contract Time or Contract Amount.
- D) On the Contract Plan Drawings and Working Drawings figured dimensions govern. Do not scale Drawings.
- E) In the case of an inconsistency between Contract Documents, the following order of precedence (from highest to lowest) applies:
- Contract
 - Addenda
 - IFB Documents
 - Specifications
 - Drawings
- F) Conditions or Work not covered by Specifications may be described in other Contract Documents and shall be performed by the Contractor in accordance therewith and in accordance with the Specifications insofar as applicable. Work required by the Contract Documents for which a separate price is not provided in the Contract Documents shall nevertheless be considered as a part of the Work and all costs of the same are deemed to be included in the Contract Amount.
- G) If any parts of the Contract require Work that does not include a description for how the Work is to be performed, the Work shall be performed in accordance with standard trade practice(s). For purposes of the Contract, a standard trade practice is one having such regularity of observance in the trade to justify an expectation that it will be observed by the Contractor in doing the Work.

- H) In the event of a conflict between the Contract Documents and applicable laws, codes, ordinances, regulations or orders of governmental authorities having jurisdiction over the Work or any portion thereof, or in the event of any conflict between such applicable laws, codes, ordinances, regulations or orders, the most stringent requirements shall govern and be considered as a part of this Contract in order to afford Kitsap Transit the maximum benefits thereof.
- I) The organization of the Specifications and arrangement of Plans shall not control the Contractor in dividing the Work among Subcontractors or in establishing the extent of the Work to be performed by any trade. Kitsap Transit assumes no responsibility to act as arbiter in the division and proper coordination of the Work between particular Subcontractors or workers.

3.2 KITSAP TRANSIT – GENERAL RESPONSIBILITIES

- A) Kitsap Transit, as Owner, shall designate a representative (“Engineer”) from the Architectural and Engineering (A/E) team who shall be responsible for coordination of communications between the Parties and shall act as a central point of contact for Kitsap Transit. Kitsap Transit shall issue all instructions to the Contractor through the Engineer.
- B) The Engineer shall review and determine that the goals, objectives and scope of this Contract are being met, as well as determining that the Schedule, budget and funding limitation of this Contract are satisfied. The Engineer will coordinate the input and Work of various governmental agency or department staff, consultants, and contractors as it relates to the Scope of Work of this Contract.
- C) The Engineer will review all Working Drawings, product data, samples or other submittals necessary to determine conformity to the Project scope, design concept and the information provided in the Contract Documents. Neither the Engineer’s review nor approval thereof shall in any way relieve the Contractor from its full responsibility for errors and omissions in the submittals or its obligations under this Contract; nor constitute acceptance by the Engineer of the correctness or adequacy of such submittals; nor constitute a representation or warranty by the Engineer that the Record Drawings will satisfy the requirements of the Contract. The Engineer will not review submittals that depend for their review on other submittals not yet submitted, that are not required by the Contract Documents, or that are not submitted by the Contractor.
- D) The Engineer will perform ten (10) on-site visits and related paperwork. The Engineer will promptly observe tests, inspections or approvals required by the Contract Documents and where practicable. The presence of the Engineer, or other Kitsap Transit representative, during the progress of any construction does not relieve the Contractor from responsibility for defects in the Work nor does it bind Kitsap Transit in determining Final Completion of the Work.
- E) Kitsap Transit and the Engineer have the authority, but not the obligation, to reject Work that is defective or does not otherwise appear to conform to the Contract Documents. The Engineer may call to the attention of the Contractor Work done or materials furnished which, at any time, is found defective or not in conformance to the Contract Documents; however, the failure of the Engineer to so inform the Contractor shall not constitute approval or acceptance of such defective or non-conforming Work. All defective or non-conforming Work shall be repaired or replaced, as directed by the Engineer, at the Contractor’s risk and expense and shall furnish no basis for an increase in the Contract Amount or Contract Time, even though the Engineer fails to reject such Work or material. The right of Kitsap Transit, or the Engineer, to reject Work shall not create a duty on the part of Kitsap Transit to exercise this right for the benefit of the Contractor or any other person or entity.
- F) Nothing in this Section or elsewhere in the Contract Documents shall be construed as requiring Kitsap Transit and the Engineer, or other representative of Kitsap Transit, to: 1) direct or advise

the Contractor as to the method or manner of performing the Work or for safety precautions or programs incidental thereto, these being the sole responsibility of the Contractor; and 2) be responsible for the acts or omissions of the Contractor, Subcontractors, lower tier Subcontractors, suppliers, or any of their agents, employees, or any other persons performing a portion of the Work. No approval or advice given by Kitsap Transit, or its representatives, as to the method or manner of performing the Work or procuring materials to be furnished shall constitute a representation or warranty by Kitsap Transit that the result of such method or manner will conform to the Contract Documents or achieve the desired results. Such approval or advice shall neither relieve the Contractor of any of its obligations under the Contract nor create any liability to Kitsap Transit, or its representatives, on account of approval or advice.

- G) The Engineer, in consultation with the Kitsap Transit Project Manager, will make decisions on all claims or requests for interpretation submitted by the Contractor, and all of the decisions are final.
- H) Kitsap Transit and the Engineer shall, at all times, have access to the Work whenever the Work is in preparation or progress. Kitsap Transit reserves the right to perform additional Work or conduct Kitsap Transit operations on or near the site of the Project. Should such other or additional Work or Kitsap Transit operations be either underway or subsequently undertaken at or near the Project, the Contractor shall coordinate its activities with those of all other Work forces and conduct its activities to avoid or minimize any conflict between the operations of the Contractor and those persons performing the other or additional Work or operations. Such use or occupancy by Kitsap Transit or its assignees shall not constitute completion or acceptance of the Work or any part thereof.
- I) Neither the Kitsap Transit Board of Directors, nor Executive Director, or any other officer, employee, or agent of Kitsap Transit acting within the scope of their employment, shall be personally liable to the Contractor for any of their acts or omissions arising out of the Project. Kitsap Transit reserves the right to perform construction operations with their own forces or to Award other Contracts in connection with the other portions of the Project or other Work on the site under these or similar conditions of the Contract.
- J) The post-award administration of the Contract file documentation will be the responsibility of Kitsap Transit to ensure compliance with the terms of the Contract and grant reporting requirements.

3.3 CONTRACTOR – GENERAL RESPONSIBILITIES

- A) Unless otherwise specifically noted, the Contractor shall provide and pay for all labor, materials, equipment, tools, construction equipment and machinery, utilities, transportation, and other facilities and services necessary for the proper execution of the Work to completion, whether the same are temporary or permanent and whether or not incorporated or to be incorporated into the Work. The Contractor shall pay all sales, consumer, use and other similar taxes and pay for all fees, duties, and royalties required by law and shall file all notices, secure all permits, and licenses necessary for the execution of the Work.
- B) The Contractor shall be solely responsible for, and shall have full control and charge of, all construction means, methods, safety precautions, techniques, sequences, and procedures for performing, scheduling and coordinating all portions of the Work under the Contract in a proper fashion and in strict compliance with all applicable codes, rules, regulations and laws. In the event of conflicting requirements between applicable codes, rules, regulations and laws, the Contractor shall comply with those codes, rules, regulations and laws which require the highest standard of construction quality and workmanship.

- C) The Contractor shall carefully study and compare the Contract Document sections with each other, and with any other information furnished by Kitsap Transit, and shall at once report to the Engineer any error, inconsistency, omission, or variance from applicable laws, statutes, codes, ordinances, or regulations which is discovered. If the Contractor performs any construction activity without carefully studying and comparing the Contract Documents, or fails to promptly report the discovery of any error, inconsistency, omission or variance in the Contract Documents, then the Contractor shall assume full responsibility therefore and shall bear all costs, liabilities and damages attributable for corrections of such error, inconsistency, omission, or variance. Omissions from the Specifications, or miss-described details of the Work which are manifestly necessary to carry out the intent of the Specifications or which are customarily performed, shall not relieve the Contractor from performing such omitted or miss-described details of Work, but they shall be performed as if fully and correctly set forth and described in the Specifications.
- D) The Contractor is responsible to field measure existing site conditions and verify casework pieces will accurately fit within the parameters as indicated on the Drawings.
- E) The Contractor shall be responsible for inspection of portions of the Work already performed under this Contract to determine that such portions are in proper condition to receive subsequent Work. Required certificates of testing, inspection or approval shall, unless otherwise required by the Contract Documents, be secured by the Contractor and promptly delivered to the Engineer.
- F) The Contractor shall afford other Contractors reasonable opportunity for the introduction and storage of their materials and equipment and for the execution of their Work or business. The Contractor shall properly coordinate this Work with that of Kitsap Transit or other Contractors.

3.4 SUB-AGREEMENTS

- A) The Contractor shall, in all its subcontract agreements, ensure that all Subcontractors are bound to the Contractor in the same manner that the Contractor is bound to Kitsap Transit, in strict accordance with all terms and conditions of the Contract Documents. Copies of any or all Subcontractor agreements shall be furnished to Kitsap Transit at the beginning of the Project. The Contractor shall also ensure that all sub-contracts meet the "Subcontractor Bidder Responsibility Criteria" set forth in these documents.
- B) Nothing contained herein; however, shall be interpreted as creating a contractual relationship between Kitsap Transit and any Subcontractor. The Contractor is for all purposes an independent Contractor and not an employee or agent of Kitsap Transit.
- C) **Subcontractors List:** The Contractor, at the request and direction of KT, will provide copies of any written agreements for approval of each Subcontractor after Contract Award.

3.5 SUBCONTRACTOR BIDDER RESPONSIBILITY CRITERIA

- A) RCW 39.06.020 requires Public Works Contractors and Subcontractors to verify that any Subcontractors they directly hire meet the responsibility criteria for the Project at the time of subcontract execution. In addition to verifying the mandatory Bidder responsibility criteria listed above from RCW 39.04.350(1), the Contractor or Subcontractor must also verify that a Subcontractor possesses an electrical Contractor license, if required by Chapter 19.28 RCW, or an elevator Contractor license, if required by Chapter 70.87 RCW.
- B) The Contractor shall include the language of this Section in each of its first tier subcontracts, and shall require each of its Subcontractors to include the same language of this Section in each of their subcontracts, adjusting only as necessary the terms used for the contracting parties. The verification requirements and responsibility criteria must be included in every

Public Works subcontract, regardless of tier. The Contractor shall certify that this verification is complete prior to Contract execution and, upon request of Kitsap Transit, shall promptly provide documentation demonstrating that the Subcontractor meets the Subcontractor responsibility criteria below.

- C) At the time of subcontract execution, the Contractor shall verify that each of its first tier Subcontractors meets the following Bidder responsibility criteria:
- 1) Have a current certificate of registration as a Contractor in compliance with Chapter 18.27 RCW, which must have been in effect at the time of subcontract Bid submittal;
 - 2) Have a current Washington Unified Business Identifier (UBI) number;
 - 3) If applicable, have:
 - (a) Industrial Insurance (Worker's Compensation) coverage for the Subcontractor's employees working in Washington State, as required in Title 51 RCW;
 - (b) A Washington Employment Security Dept. number, as required in Title 50 RCW;
 - (c) A Washington Department of Revenue state excise tax registration number, as required in Title 82 RCW;
 - (d) An electrical Contractor license, if required by Chapter 19.28 RCW;
 - (e) An elevator Contractor license, if required by Chapter 70.87 RCW.
 - 4) Not be disqualified from Bidding on any Public Works Contract under RCW 39.06.010 or 39.12.065(3).

3.6 PROTECTION OF EXISTING PROPERTY

The Contractor shall protect from damage all existing Structures, curbs, sidewalks, equipment, improvements, utilities, trees, and vegetation located at or near the Work site which are not considered part of the Work to be performed under the Contract. Damages or losses that may occur shall be the responsibility of the Contractor, except those caused by the acts or omissions of Kitsap Transit. The Contractor shall promptly repair, at no cost to Kitsap Transit, any such damage resulting from failure to comply with the requirements of the Contract or failure to exercise reasonable care in performing the Work. If the Contractor fails or refuses to repair the damage promptly, Kitsap Transit may have the necessary Work performed and deduct or charge the cost back to the Contractor. Prior to beginning the Work, the Contractor shall give proper notification, as required by RCW 19.122.030, to the agencies that have utilities in place and shall cooperate with these agencies in the protection and relocation of underground utilities, facilities and Structures.

3.7 SAFETY STANDARDS

The Contractor agrees to comply with all Federal, State and local laws, ordinances, and regulations, as may be amended, which might affect those engaged in the Contract Work. Industry standards and applicable laws and regulations of authorities having jurisdiction include, but are not limited to, the following: Washington Industry Safety and Health Act of 1973 (WISHA); Federal Occupational Safety and Health Acts of 1970 (OSHA); WA State Department of Labor & Industries – Title 296 WAC; Utility company regulations; the National Electric Code (NEC); the National Fire Protection Association (NFPA) Standards; Environmental Protection regulations; etc. It shall be the Contractor's responsibility to comply with "Safety and Health Regulations for Construction", Volume 36, No. 75, Part II of the Federal Register by the U.S. Department of Labor.

3.8 SPECIAL REPORTS

When an event of an unusual and significant nature occurs at the site, including an accident where personal injury or property loss is sustained, or where the event posed a significant threat of loss or personal injury, the Contractor shall prepare and submit a special report which shall list: chain of events, persons participating, response/action by Contractor's personnel, and evaluation of the

results or effects and similar pertinent information. Submit special reports directly to the Kitsap Transit Project Manager within one (1) day of an occurrence. Submit a copy of the report to the Engineer and other entities that are affected by the occurrence.

3.9 WORKING DRAWINGS, PRODUCT DATA, SAMPLES AND OTHER SUBMITTALS

- A) The Contractor shall, with reasonable promptness, review, stamp with its approval, and submit all Working Drawings, product data, samples, and other items required by the Contract Documents, to the Engineer for concurrence that the submittals conform to the design concept and the information given in the Contract Documents. By submitting such documents, the Contractor represents that it has determined and verified all materials, field measurements, and related field construction criteria are in accordance with the Contract Documents, and that the Contractor has checked and coordinated the information contained with the submittal for accuracy and completeness, and with the requirements of the Work and the Contract Documents. The costs incurred by Kitsap Transit to review resubmitted Working Drawings, product data, and samples may be offset from any monies due the Contractor when the Contractor has failed to comply with this paragraph.
- B) Any Work delayed by reason of a properly rejected submittal is deemed to be entirely the Contractor's risk, and shall not be the basis for a claim by the Contractor for additional compensation or an extension of Contract Time. When resubmitting a submittal, the Contractor shall direct specific attention, in writing or on the re-submittal itself, to all revisions it has made. Drawings marked "subject to change" or the like will not be reviewed. Kitsap Transit is not required to review submittals that depend for their review on other submittals not yet submitted.
- C) No portion of the Work requiring submittal of a Working Drawing, product data, or sample shall be commenced until the submittal has final approval by Kitsap Transit. All portions of the Work involving submittals shall be performed in accordance with the approved submittals.

3.10 RECORD DOCUMENTS

When requested, or upon completion of the Work, the Contractor shall furnish Kitsap Transit with Record Drawings and Specifications certified by an Engineer showing all deviations from the original (at the time of Bid submittal) Contract Documents. Drawings and Specifications shall show actual dimensions, locations, approved changes, options and alternates made during construction. Include type of equipment, make, model, serial number, and acquisition cost of installed capital equipment or other fixed assets. The Engineer may use Record Drawings to verify the appropriate progress payment.

3.11 ADMINISTRATIVE AND SUPERVISORY PERSONNEL

- A) The Contractor shall be fully responsible to Kitsap Transit for the acts, errors and omissions of all its employees, agents, Subcontractors, lower tier Subcontractors, suppliers, and their agents and employees, and all other persons who are to perform any of the Contract Work. All Work shall be performed under the supervision and direction of competent and skilled personnel experienced in the tasks being performed.
- B) The Contractor shall at all times enforce strict discipline and good order among all workers on the Project and shall not employ on the Work any unfit person or anyone not skilled in the task assigned. Incompetent, careless, or negligent workers shall be immediately removed from the performance of the Work by the Contractor or at the express direction of Kitsap Transit.
- C) The Contractor shall employ a General Superintendent and necessary assistants who shall be in attendance at the Project site during performance of the Work and shall supervise and direct the Work as per industry standard. The General Superintendent shall be the Contractor's representative and shall have authority to act on behalf of and bind the Contractor with respect to this Contract, except that the Contractor may indicate in writing limits on the authority of the

superintendent. Communications or notices directed or given to the General Superintendent shall be as binding as if given to the Contractor. The General Superintendent shall not be replaced without prior written notice to Kitsap Transit.

- D) Within ten (10) calendar days of a written Notice To Proceed, the Contractor shall submit to Kitsap Transit a listing of its principal staff assignments, consultants and Subcontractors; naming persons and listing their telephone numbers.

3.12 GENERAL GUARANTEE AND WARRANTIES

- A) The Contractor warrants to Kitsap Transit that all goods, materials and equipment furnished under this Contract will be of highest quality and new, unless otherwise specified by Kitsap Transit; free from liens, faults and defects and in conformance with the Contract Documents. All such materials and equipment shall be applied, installed, connected, erected, used, cleaned, maintained and conditioned in accordance with the instructions of the applicable manufacturer, fabricator or processor, unless specifically provided otherwise in the Contract Documents. Upon the request of Kitsap Transit, the Contractor shall furnish satisfactory evidence as to the kind, quality, and manufacturer of materials and equipment.
- B) The Contractor warrants to Kitsap Transit that all Work furnished will be of first quality and the workmanship will be the best obtainable in the various trades. The Work will be safe, substantial and durable construction in all respects; free from defective materials and faulty workmanship, and in conformance with the Contract Documents and the best construction practices acceptable. These provisions apply to Work done by Subcontractors and direct employees of the Contractor.
- C) The Contractor warrants that all parts of the Work shall remain in perfect working order and condition for a minimum period of one (1) year after Final Acceptance by Kitsap Transit. All Work not conforming to these standards during the construction period, the warranty period, or within such longer period of time as may be prescribed by law, or by the terms of any other applicable warranty period specified or required by the Contract Documents, shall be immediately remedied at the Contractor's sole expense. The warranty provided under this paragraph shall be in addition to any other express or implied warranties for particular equipment or Work items indicated in the Contract Documents, and in addition to other rights or remedies available to Kitsap Transit under this Contract or at law. No provision in this Article shall be construed to limit the liability of the Contractor for Work not performed in accordance with the Contract. The liability for such failure to perform shall extend as far as the appropriate periods of limitation provided by law. Acceptance of any service and inspection incidental thereto by Kitsap Transit shall not alter or affect the obligations of Contractor or the rights of Kitsap Transit. Any defects shall be immediately remedied by the Contractor.
- D) Kitsap Transit shall immediately give written notice to the Contractor of any defective goods or services discovered within said warranty period. If the Contractor has not corrected the defect within thirty (30) calendar days after receiving the written notice, or Kitsap Transit determines the Contractor's corrective action is not satisfactory, Kitsap Transit, in its sole discretion, may correct the defects itself. In the case of an emergency where Kitsap Transit believes delay would cause serious injury, loss or damage, Kitsap Transit may waive the written notice and correct the defect. In either case, the Contractor and its Surety are responsible for all expenses incurred and Kitsap Transit will charge-back the cost for such warranty repair to the Contractor, including shipping charges, regardless of who actually corrects the defect.
- E) The Contractor shall further make good all damage to the Project site, or equipment or contents thereof which, in the opinion of Kitsap Transit, is the result of the use of materials, equipment or workmanship which is inferior, defective, or not in accordance with the terms of the Contract;

and shall make good any Work or materials, or the equipment and contents of building, Structures, or site disturbed in fulfilling any such warranty.

- F) Upon completion of the Work, the Contractor shall furnish to Kitsap Transit any guaranty or warranty furnished as a normal trade practice in connection with the Contractor's purchase of any equipment or materials; provided such guaranty or warranty shall be in addition to those specific requirements for particular equipment or Work items indicated elsewhere in the Contract Documents. The Contractor will maintain copies of all warranty information and shall cooperate with Kitsap Transit to immediately facilitate any warranty related Work to satisfactorily repair the condition, correct the defect, error, or non-conformity at the Contractor's sole expense.
- G) All extended warranties provided by a manufacturer or vendor must be passed on to Kitsap Transit, without exception. The Contractor is responsible for liability and expense caused by any inconsistencies or differences between the warranties extended to Kitsap Transit by the Contractor and those extended to the Contractor by its suppliers, vendors, distributors and Subcontractors. Such inconsistency or difference will not excuse the Contractor's full compliance with its obligations under this Contract. Required repairs not covered by the Manufacturer's Warranty because of the Contractor's deviation of the methods will be made by the Contractor at no expense to Kitsap Transit. If the Contractor charges Kitsap Transit for a replacement part that the Contractor actually received at no cost under a warranty, the Contractor will rebate Kitsap Transit the amount billed.
- H) If the Contractor performs Work at the job site under these warranty provisions, the Contractor shall furnish insurance coverage therefore as specified in the Contract Documents. Prior to beginning such Work, the Contractor shall furnish certification of insurance satisfactory to Kitsap Transit.
- I) The Contractor further warrants that no violation of any Federal, State or local law, statute, rule, regulation, ordinance or order will result from the manufacturer, production, sale, shipment, installation or use of any other goods.
- J) The Contractor's warranty responsibilities shall survive delivery, inspection, acceptance of the goods or services, and Contract termination. Neither Final Acceptance, or partial or entire use or occupancy of the Work (Substantial Completion), by Kitsap Transit shall constitute an acceptance of Work not done in accordance with the Contract or relieve the Contractor of liability in respect to any expressed warranties or responsibility for faulty materials and workmanship.
- K) Warranties shall not apply to Work or materials that have been abused or neglected by Kitsap Transit. Abuse means damage or degradation resulting from accidents, deliberate actions or omission other than normal wear and tear of the user. The Kitsap Transit Project Manager, or designee, will be the final arbitrator for issues involving abuse versus normal wear and tear.

3.13 PREVAILING WAGE REQUIREMENTS

- A) As required by Chapter 39.12 RCW, wage rates to be paid all laborers, workers, and mechanics performing any part of this Contract, whether they are employed by the Contractor, Subcontractors, or lower-tiered Subcontractors, or any other person who performs a portion of the Work completed by this Contract, shall not be less than the Washington State prevailing wage rates paid for an hour's Work in the same trade or occupation in the County that the work is performed. The Contractor is required to pay the applicable prevailing wage rates in effect upon October 16, 2020, the Bid Due Date, which shall remain in effect for the duration of the Contract. A copy of the applicable wage rates is available for viewing at Kitsap Transit's Harborside Building. A hard copy will be mailed upon request.

- B) **Washington State Prevailing Wages:** May be found at the website address of the Department of Labor and Industries: <https://fortress.wa.gov/lni/wagelookup/prvWagelookup.aspx>. Kitsap Transit does not imply or warrant that the Contractor will find labor available at those rates.
- C) **Reserved**
- D) **Wage Determinations:** It is the Contractor's sole responsibility to determine the category of prevailing wages it will have to pay. If more than one category of Work is applicable to the Project, the Contractor shall list them on the "*Statement of Intent to Pay Prevailing Wages*". If the Contractor is employing labor in a class not listed on the State schedule, the Contractor shall immediately contact the Industrial Statistician of the Washington State Department of Labor and Industries to determine the correct wage rate for that class and locality. The Statistician's decision shall be final, conclusive and binding on all parties.
- E) **Intent and Affidavits:** No payment will be made on this Contract until the Contractor and each and every Subcontractor, regardless of tier, has submitted to Kitsap Transit a "*Statement of Intent to Pay Prevailing Wages*" that has been approved by the Industrial Statistician of the Washington State Department of Labor and Industries (L&I). No release of retainage will be made until the Contractor and each and every Subcontractor has submitted to Kitsap Transit an "*Affidavit of Wages Paid*" that has been approved by L&I's Industrial Statistician. A receipt from L&I for filing these required prevailing wage documents is not an approval.
- F) **Filing Requirements:** Kitsap Transit recommends that Intent and Affidavit forms be submitted electronically with Labor and Industries to expedite verification of submittal; however, Kitsap Transit will accept copies of approved forms submitted through paper procedures. In compliance with WAC 296-127, the Contractor agrees to pay L&I the appropriate processing fee for each Intent and Affidavit submitted to that Department for certification. All costs associated with such fees shall be included in the Bid Price as part of the fixed costs of overhead for this Contract, including any anticipated sub-contractor filing fees. Any change in the fee by L&I will not be grounds for revision in the Contract Amount.
- G) **Posting of Notices:** The Contractor shall post the applicable prevailing wage rates in a location readily visible to workers at the job site, or as allowed by RCW 39.12.020, and shall include:
- 1) Contractor's registration certificate number;
 - 2) The prevailing rate of wage for each classification of workers entitled to prevailing wages under RCW 39.12.020; and
 - 3) The estimated number of workers in each classification.

3.14 **CONTRACT BONDS**

- A) In the event the Surety becomes unacceptable to Kitsap Transit during the course of the Contract Work, or Kitsap Transit deems the Surety or Sureties to be inadequate, it may, upon written request and at the Contractor's cost and expense, require the Contractor to furnish bonds from another Surety to cover any remaining Work. Until the added Surety is furnished, payments on the Contract will stop.
- B) **Payment Bond:** The penal amount of the Payment Bond shall be for one hundred percent (100%) of the total Contract Amount, including all Change Orders and sales tax, conditioned upon the Contractor's payment of all Subcontractors and suppliers, taxes imposed under Title 82 RCW.

- C) **Performance Bond:** The penal amount of the Performance Bond shall be for one hundred percent (100%) of the total Contract Amount, including all Change Orders and sales tax, conditioned upon the Contractor faithfully performing all of its obligations under this Contract within the time prescribed therein.
- D) Kitsap Transit may require additional bond protection if the Contract Amount is increased. The increase in protection shall equal one-hundred percent (100%) of the increase in Contract price. Kitsap Transit may secure additional protection by directing the Contractor to increase the penal amount of the existing bonds or to obtain additional bonds.

3.15 **RETAINAGE**

- A) For each payment made to the Contractor, an amount equal to five percent (5%) of the total pre-taxed amount earned by the Contractor shall be retained, including any additions or deletions by Change Order. Such amounts shall be withheld by Kitsap Transit for forty-five (45) days following the date of Final Acceptance or until any liens filed under RCW 60.28 are settled, whichever is later.
- B) **Options for Withholding:** In accordance with RCW 60.28.011, the Contractor shall inform Kitsap Transit as to how monies may be retained by Kitsap Transit by selecting one of the following options on Kitsap Transit's "*Declaration of Option For Management of Statutory Retainage*" form: 1) Deposited in a non-interest bearing account; 2) Deposited in an interest-bearing account in a bank, mutual savings bank or savings and loan association; or 3) Placed in escrow with a bank or trust company.
- C) **Optional Retainage Bond:** The Contractor may furnish Kitsap Transit, at the Contractor's cost and at Kitsap Transit's option, a retainage bond of five percent (5%) of the Contract amount to be held in lieu of actual retainage. The bond shall be issued by a corporate Surety acceptable to Kitsap Transit and licensed to do business in the State of Washington. In the event the Surety becomes unacceptable to Kitsap Transit during the course of construction, the Contractor shall, upon Kitsap Transit's written request and at the Contractor's sole cost and expenses, obtain a retainage bond from another Surety acceptable to Kitsap Transit.

3.16 **PAYMENT**

- A) Total payment shall not exceed the Contract Amount unless authorized herein by a written Change Order. Excluding retainage, and providing an L&I approved "*Statement of Intent to Pay Prevailing Wages*" for the Contractor and every Subcontractor has been received by Kitsap Transit, payment shall be made within thirty (30) days after Kitsap Transit's acceptance and approval of a properly executed invoice for Work completed. Pre-payments are not permitted.
- B) **Payment Requests:** Payment requests, including schedules, for the preceding month shall be submitted by the Contractor to the Engineer for review and certified approval prior to Kitsap Transit making any payment to the Contractor. Any subsequent changes shall be submitted at least twenty (20) days before the applicable request for payment using the agreed schedules. After the Engineer reviews the Contractor's pay request, a Certificate for Payment will be issued to Kitsap Transit to make payment within thirty (30) days of approving the invoice. Upon request of a Subcontractor, the Engineer will furnish, if practicable, information regarding percentages of completion or amounts applied for by the Contractor and action taken thereon by the Engineer and Kitsap Transit on account of portions of the Work done by such Subcontractor.
- C) **Progress Payments:** Kitsap Transit shall make monthly progress payments for Work performed by the Contractor. Progress payments will be based upon an agreed upon Schedule of Values, schedule of payments, critical milestones and any performance metrics. A

breakdown of the Contract Amount shall be provided in enough detail to facilitate continued evaluation of applications for payment and progress reports. Payments will be reduced by five percent (5%) for retainage; Contractor invoices will reflect the retainage reduction.

- D) **Prompt Payment of Subcontractors**: The Contractor shall ensure that all Subcontractors and suppliers under this Contract are promptly paid to the fullest extent required by RCW 39.04.250, as may be amended. The Contractor is required to pay each Subcontractor performing Work under this prime Contract for satisfactory performance of that Work no later than thirty (30) days after the Contractor's receipt of payment for that Work from Kitsap Transit. In addition, the Contractor is required to return any retainage payments to those Subcontractors within thirty (30) days after the Subcontractor's Work related to this Contract is satisfactorily completed and any liens have been secured. Any delay or postponement of payment from the above time frames may occur only for good cause following written approval of Kitsap Transit.
- E) **Final Payment**: Shall be the release of the retained percentage to the Contractor. Retainage shall be released thirty (30) days following the date of Final Acceptance of the Work; provided that Kitsap Transit has received the following:
- (1) An "*Affidavit of Wages Paid*" for the Contractor and every Subcontractor as approved by the Industrial Statistician of the Department of Labor and Industries;
 - (2) A release of liability from the WA State Department of Labor and Industries (L&I), WA State Department of Revenue (DOR), and the Employment Security Department (ESD), or any claims that have been paid from L&I or DOR, whichever comes first.
 - (3) Lien releases for the Contractor and each Subcontractor and supplier who performed Work and provided supplies and materials for the Project. These conditional releases will be submitted to Kitsap Transit as soon as practical after completion of the Work. Kitsap Transit may provide release forms to the Contractor for distribution. If a lien claimant refuses to furnish a release, Kitsap Transit may withhold funds to defray the cost of lien foreclosure and to pay attorney's fees in an amount no less than 150% of the lien amount.
 - (4) Satisfaction of any lien claims or unpaid claims Kitsap Transit may have against the Contractor or, where applicable, the consent of the Surety to release retainage. In the event a claim is filed against the retainage, the Contractor shall be paid any portion of the retainage that is less than the amount sufficient to pay the claim and potential legal costs. If an inadequate amount of money remains in the retainage to cover all claims due to be paid, the protections provided by the Payment Bond become applicable, excluding taxes.
- F) Payment does not in any way relieve the Contractor from its responsibility for the Work or to repair, replace, or otherwise make good defective Work, materials or equipment. Likewise, the making of any payment does not constitute a waiver of Kitsap Transit's right to reject defective or non-conforming Work, materials, or equipment, even though the same is covered by the payment, nor is it a waiver of any other rights of Kitsap Transit. Payments due and unpaid in accordance with the Contract Documents shall bear interest as specified in RCW 39.76.
- G) **Claims**: In the event a claim is filed against the retainage, Contractor shall be paid any portion of the retainage that is less than the amount sufficient to pay the claim and potential legal costs. If an inadequate amount of money remains in the retainage to cover all claims due to be paid, the protections provided by the Payment Bond become applicable, excluding taxes.

3.17 DELAYS – RESPONSIBILITY

In the event of delay to the Contractor in performing the Work resulting from the conduct or lack of conduct by Kitsap Transit or their Contractors, officers, employees, agents; or resulting from delay or failure of Kitsap Transit in making the site available; or in furnishing any items required to be

furnished to the Contractor pursuant to the Contract Documents; or resulting from changes to the Project ordered by Kitsap Transit; or resulting from:

- (1) Extraordinary conditions of weather for the area and time of year, (Extraordinary conditions of weather shall not be deemed Extraordinary if they fall within two standard deviations from the mean of data recorded by the U.S. Weather Bureau for the Seattle/Tacoma metropolitan area over the last twenty (20) years. To preclude the difficulties of actual measurement, the parties hereto agree that weather data at the site shall be expressly deemed to be the same as that measured at the Seattle-Tacoma International Airport by the Environmental data and Information Service of the National Oceanic and Atmospheric Administration (NOAA) of the U.S. Department of Commerce),
- (2) War or national conflicts or priorities arising therefrom,
- (3) Fires beyond the reasonable control of the Contractor,
- (4) Acts of God,
- (5) Strikes or other labor disruptions, except for the first five working days of any strike or labor disruption,
- (6) Any other causes beyond the Contractor's reasonable control (but not including delays caused by the Contractor, Subcontractors of any tier or suppliers); and for no other cause or causes,
- (7) Epidemic

The Contractor shall be entitled to an extension of time, and cost as appropriate, with regard to the time for completion of the Project and only by the amount of time the Contractor is actually delayed thereby in the performance of the Project, provided notice is given and claim is made, both as hereinafter provided. It shall be Contractor's burden to prove that a delay exists for which an extension of time is allowable.

3.18 SUSPENSION OF WORK

The Engineer may, with Kitsap Transit's approval, direct that all or any part of the Work be suspended for such time period as the Engineer deems proper because of unsuitable weather or other conditions beyond the control of Kitsap Transit and the Contractor, which prevents satisfactory performance of the Work. The Contractor shall immediately comply with the directive to suspend Work. The Contractor shall resume the suspended Work when so directed by the Engineer. Such suspension of Work shall not be grounds for a claim by the Contractor for an increase in the Contract Amount; however, Contract Time may be adjusted in accordance with the provisions herein unless the Engineer concludes that the Contractor could have performed the suspended Work if the Contractor had diligently prosecuted the Work prior to such suspension. Kitsap Transit may also suspend Work for its convenience and without cause, after giving the Contractor ten (10) days written notice. In the event such suspension causes a change in the Contractor's cost or time of performance of the Work, the Contractor shall be entitled to make a claim for a change in Contract Time and Contract Amount as set forth elsewhere herein.

3.19 KITSAP TRANSIT'S RIGHT TO STOP WORK

If the Contractor fails to perform the Work in accordance with the Contract Documents, fails to correct defective Work, or fails to comply with any other directive issued by Kitsap Transit, Kitsap Transit may order that the Contractor stop all or any portion of the Work until the cause for such order is eliminated. In the event of an order to stop Work, the Contractor shall not be entitled to any increase in the Contract Time or Contract Amount, nor to any damages or relief from liability, on account of such order to stop Work.

3.20 DISRUPTIONS CAUSED BY LABOR OR OTHER DISPUTES

- A. The term “dispute” as used in this paragraph includes labor-related and non-labor-related disputes, whether or not the persons or other entities involved in the dispute have an employment relationship with either the Contractor or Kitsap Transit. Examples of such disputes include, but are not limited to: informational or other picketing, and all other forms of concerted or non-concerted activity. The Contractor shall pay all attorneys’ fees and expenses incurred by Kitsap Transit in establishing and enforcing Kitsap Transit’s rights whether or not suit was instituted.
- B. The Contractor shall take all reasonable steps to prevent all disputes arising from the presence of or the performance of the Work by the Contractor, its Subcontractors and lower tier Subcontractors, suppliers, or other persons performing any of the Work, from disrupting the Project or otherwise interfering with access to Kitsap Transit property by Kitsap Transit, its agents, employees, tenants or employees thereof, or other Contractors engaged on or near the site of the Project. If such a dispute disrupts the Project or interferes with access to Kitsap Transit property, the Contractor shall promptly and expeditiously take all reasonable action to eliminate or minimize such disruption or interference, including but not limited to:
- Utilizing all reasonable means to prevent all unlawful conduct or picketing, or to restrict all lawful picketing or other activities to a single entrance to Kitsap Transit property;
 - Policing entrances to assure that only authorized personnel may use the same;
 - Posting notices or signs which advise interested persons and labor organizations that a particular entrance to Kitsap Transit property is for the employees of “primary” or, as the case may be, “neutral” employers;
 - Notifying all interested labor organizations or the “primary” or “neutral” status of particular entrances;
 - Upon request of Kitsap Transit, altering or rerouting the access to the Project;
- C. In the event any such picketing or activity is unlawful or has a secondary impact upon the employees of neutral employers, tenants or their suppliers or Contractors, promptly and expeditiously taking appropriate action to seek recourse through the appropriate governmental agency or State or Federal courts to limit the location of such picketing so as to reduce the impact thereof upon neutral employers. Kitsap Transit will cooperate with the Contractor to accomplish the foregoing actions and will render its assistance where appropriate; however, Kitsap Transit shall have the right, without providing additional compensation to the Contractor, to direct the Contractor to modify any of the foregoing actions which the Contractor has taken or plans to take, or to overrule such actions, to designate the entrances to be used as “primary” or “neutral” entrances, and to take appropriate legal action in order to protect the interests of Kitsap Transit and those of its tenants and other Contractors.
- D. The foregoing actions to be taken by the Contractor are the Contractor’s primary responsibility. Neither the failure of Kitsap Transit to request the Contractor take a specific action, nor the exercise by Kitsap Transit of its rights under this paragraph, shall modify, constitute a defense to, or waiver the obligations imposed upon the Contractor in this paragraph. Failure to take the action described above or to comply with the directives of Kitsap Transit shall be considered a material breach of the Contract.

3.21 CHANGES IN THE WORK AND CHANGE ORDERS

- A) Change Orders shall be the only acceptable way to modify the Contract Amount or Contract Time. No oral statement by any person shall change or modify the Contract. Should any changes to the Contract Work be required, the Contractor or Kitsap Transit shall refer same to each other before Work which deviates from the original requirements is started. All mutually agreed upon changes must be made in writing and incorporated into the Contract Documents through the execution of a Change Order by Kitsap Transit, or the Engineer, which shall provide for any increase or decrease in the Contract Time, Contract Amount, or both as caused by such change. Such changes shall not invalidate or nullify any portion of the Contract Documents nor

release the Contractor's Surety. In event of disagreement on the necessity of such changes, Kitsap Transit's decision shall be final.

B) **Contractor Requested Changes:** Any other written or oral direction, instruction, interpretation or determination (collectively, "order") from any source that the Contractor believes may cause any change in cost, in time, or both, shall be treated as a Change Order under this clause; provided that the Contractor gives Kitsap Transit written notice within five (5) calendar days of having known of the occurrence of the event giving rise to the change. The notice must state the date, circumstances, cost details, time implications, source of the order and a certification that the Contractor regards the order as a necessary change. The Contractor's Change Request shall be full compensation for implementing the proposed change in the Work, including any adjustment in the Contract Amount and/or Contract Time, including compensation for all delays in connection with such change in the Work and for any expense or inconvenience, disruption to schedule, or loss of efficiency or productivity occasioned by the Change in Work.

C) **Owner Directed Changes:**

(1) Kitsap Transit may make at any time during the Work, without notice to the Surety and by written order designated or indicated to be a Change Order, any changes in the Work within the general scope of the Contract, including but not limited to the following:

- Deleting any part of the Work;
- Increasing or decreasing quantities;
- Altering Specifications, designs, or both;
- Altering the way Work is to be done;
- Adding new Work;
- Altering Kitsap Transit-provided facilities, equipment, materials, services, or sites; or
- Directing acceleration or delay in the performance of the Work.

(2) For any change requested by Kitsap Transit, the Contractor shall submit to the Engineer, within seven (7) calendar days of Kitsap Transit's request, a detailed price and time schedule proposal supported with documentation that reflects all cost and time related impacts on the Contract. The proposal shall be prepared in accordance with provisions hereunder and shall include a complete breakdown of direct costs of both deletions and additions directly attributable to the proposed change in the Work.

(3) Any Field Directive, response to Requests for Information (RFI), or other written directive, interpretation, instruction or determination (hereinafter referred to as "Direction") provided by Kitsap Transit or the Engineer, is not considered a Change Order or a change to Contract requirements and shall not constitute, in and of itself, entitlement to an adjustment in Contract Price, Contract Time, or both.

D) **Cardinal Change:** Any change exceeding twenty-five percent (25%) of the Contract Amount is considered a "Cardinal Change" and will not be permitted regardless of whether or not the change is "in-scope" or a significant change. For purposes of this Contract, a significant change is when the character of the Work as altered differs materially in kind or nature from that originally included in the solicitation.

E) **Time Extension:**

(1) Requests for a time extension shall only be limited to the effect on the Critical Path of the Contractor's approved Progress Schedule attributable to the change or event giving rise to the request. As used herein, "Critical Path" means the longest, continuous sequence of interrelated activities that begins on the date Kitsap Transit issues a Notice To Proceed and extends to Substantial or Final Completion of the Project.

- (2) To be considered, the request shall be in sufficient detail to enable the Engineer to ascertain the basis and amount of the time requested. The request shall include an updated schedule that supports the request and demonstrates that the change or event: (1) Had a specific impact on the Critical Path, and except in cases of concurrent delay, was the sole cause of such impact; and (2) Could not have been avoided by resequencing of the Work or by using other reasonable alternatives.
- (3) In evaluating any request, the Engineer will consider how well the Contractor used the time from the Notice to Proceed up to the point of the delay and the effect the delay has on any completion times included in the Specifications or Scope of Work. The Engineer will evaluate and respond within seven (7) calendar days of receiving the request.
- (4) The authorized time for Physical Completion will be extended for a period equal to the time the Engineer determines the Work was delayed because of: Adverse weather, providing the Engineer had not already declared the time to be unworkable and the Contractor has filed a written protest according the provisions herein; Any action, neglect, or default of Kitsap Transit, its officers, or employees, or of any other Contractor employed by Kitsap Transit; Fire or other casualty for which the Contractor is not responsible; Strikes; and Any other conditions for which these Specifications permit time extensions.

F) **Equitable Adjustment:**

- (1) Except as specifically provided for herein, the Contractor is not entitled to an equitable adjustment, and Kitsap Transit will have no obligation or liability, on account of a change in the Work that is not made through a properly executed Change Order. The method of how a Change Order will be priced, be it negotiated lump sum or unit price, is solely at Kitsap Transit's discretion. Nothing in this Section shall be deemed to require a change in the Contract Amount when additional, extra, or changed Work is the result of an estimating, contracting or engineering error by the Contractor. In no event shall the Contractor be entitled to compensation for the loss of anticipated profits on deleted, terminated, or uncompleted Work or consequential damages of any kind. No claim by the Contractor for an equitable adjustment hereunder shall be allowed if asserted after Final Payment under this Contract.
- (2) If any change under this provision causes an increase or decrease in the Contractor's cost of, or the time required for, the performance of any part of the Work under this Contract, whether or not changed by any order, an equitable adjustment shall be made and the Contract modified in writing accordingly, provided; however, that except for claims based on defective Specifications, no claim for any Contractor requested change shall be allowed for any costs incurred more than seven (7) calendar days before the Contractor gives proper written notice as herein required; and provided further, that in the case of defective Specifications for which Kitsap Transit is responsible, the equitable adjustment shall include any increased cost reasonably incurred by the Contractor in attempting to comply with such defective Specifications.
- (3) If the Contractor intends to assert a claim for an equitable adjustment under this paragraph, it must, within seven (7) calendar days after receipt of a written Change Order by Kitsap Transit, or the furnishing of a written notice to Kitsap Transit, submit to Kitsap Transit a written proposal ("**Change Request**") further setting forth the general nature, time implications, monetary extent of such claims, and a certification that the Contractor regards the order as a necessary change, unless this period is extended by Kitsap Transit. The Contractor may request, in writing, an extension in time to submit the Change Request.
- (4) The Contractor's Change Request shall include detailed price calculations for the proposed change, which shall itemize the cost of all labor, materials, equipment, and any other

allowable direct costs for the Contractor and, further, shall be accompanied by the signed Bids of any Subcontractors or suppliers who will perform any portion of the change in the Work or will furnish materials or equipment for incorporation therein. Each labor classification shall be broken out in detail. Any aggregate labor total will NOT be acceptable. The Contractor's Change Request shall also show as a separate item, the proposed amount for markup, contingency, overhead and fee.

No allowance for increasing the bonds will be made. The same level of detail required for the Contractor's Change Request shall be included in all Subcontractor quotations.

- (5) Overhead and profit percentage markups shall not exceed those specified as allowed under this Section and shall be deemed to cover all costs and expenses of any nature whatsoever, including without limitation those for general condition items such as clean-up, protection, supervision, estimating, field operations, small tools and security, which the Contractor or any of its Subcontractors may incur in the performance of or in connection with a Change in the Work and which are not otherwise specifically recoverable by them pursuant to this Section. The parties agree and acknowledge that the adjustments to Contract Amount and Contract Time, if any, contained in a Change Order shall constitute the total and complete compensation and remedy for the Change in the Work, including any effect of the individual change and any cumulative effects prior to Change Orders on the Work as a whole, and all direct and indirect costs of whatsoever kind or nature, including, without limitation, overhead, extended overhead, profit, impact costs, ripple costs, delay costs, inefficiency costs, and all other special, incidental and consequential damages.
- (6) Upon receipt of the Contractor's fully documented Change Request, Kitsap Transit may accept or reject the Request, request further documentation, negotiate acceptable terms with the Contractor, or inform the Contractor that additional time is needed to evaluate the Change Request. Under such circumstances, Kitsap Transit will identify a date certain when a decision on the Change Request will be made. For any Change Request which has merit, Kitsap Transit will initiate a written Change Order to the Contract. If Kitsap Transit and the Contractor reach an agreement on the terms and conditions of the Change Request, including any adjustment in Contract Amount or Contract Time, such agreement shall be incorporated into a Change Order and signed by both parties. This bilateral Change Order shall represent full and complete payment, time adjustments, and final settlement of all changes and claims for direct, indirect, and consequential costs, including cost of delays, inconvenience, disruption of schedule, or loss of efficiency or productivity, related to any Work either covered or affected by the Change Order, or related to the events giving rise to the bilateral Change Order.
- (7) If the change in the Work will result in a decrease in the Work to be performed on the Project, the Contract Amount will likewise be decreased by an amount equal to the estimated cost of the Work as contained in the Contractor's or Subcontractors' underlying Bid, Bid, or Schedule of Values. Further, if such decrease in the Work will result in a decrease in the time required to complete the Project, then the Contract Time will be reduced by the length of time fairly attributable to such decrease in the Work.
- (8) If Kitsap Transit and the Contractor are unable to reach an agreement on the terms and conditions of the Change Request, including any adjustment in Contract Amount or Contract Time, the Contractor may request in writing, at any time, a final offer from Kitsap Transit. Kitsap Transit shall provide the Contractor with its written response within thirty (30) calendar days of the Contractor's request. Kitsap Transit may also provide the Contractor with a final offer at any time. If the Contractor rejects Kitsap Transit's final offer, or the parties are otherwise unable to reach agreement, the Contractor's only remedy shall be to file a claim as provided in the claims section.

G) **Unilateral Change Order:** If Kitsap Transit and the Contractor are unable to reach an agreement concerning adjustment in the Contract Amount or Contract Time caused by a change in the Work, Kitsap Transit may unilaterally issue a Change Order in its sole discretion without invalidating the Contract and without notice to the Surety, implementing changes within the general scope of the Contract and directing the Contractor to perform the Work as changed. The Change Order may embody such terms as Kitsap Transit deems appropriate and the Contractor shall promptly and diligently perform the Work in the most efficient, economical, and workmanlike manner, consistent with the best interest of Kitsap Transit, and shall not slow or stop the progress of the Work pending resolution of any such disputes. The Contractor shall be entitled to seek compensation in the Contract Amount or Contract Time to the extent directly caused by the change in Work. If the Contractor disagrees with the adjustment in Contract Price or Contract Time as indicated in the Unilateral Change Order, it may file a claim in accordance with Paragraph 4.27 – Claims. Unless Kitsap Transit agrees in writing to the contrary, the Contractor shall only be permitted to perform changes in the Work with its own forces if the Contractor was the entity that performed, or was contemplated to perform, the original Work of the trade in question.

H) **Differing Site Conditions:**

- (1) In the event the Contractor encounters: (1) pre-existing subsurface or latent physical conditions at the worksite which differ materially from those indicated in the Contract Documents; or (2) unknown physical conditions of an unusual nature at the worksite which differ materially from those ordinarily encountered and generally recognized as inherent in the Work of the character provided for in the Contract Documents, and such conditions cause an increase in Contractor's cost or time of performance, the Contractor may be entitled to an equitable adjustment in the Contract Time, Contract Amount, or both.
- (2) The Contractor shall promptly notify the Engineer orally of such encounter and, no later than seven (7) calendar days after having known of the occurrence and before the conditions are disturbed, the Contractor shall furnish Kitsap Transit written notice of the changed conditions or other conditions for which an equitable adjustment in Contract Amount or Contract Time is desired.
- (3) If such notice is not given prior to the condition being disturbed, or other action being taken by the Contractor which may result in a claim for an increase in the Contract Time or the Contract Amount, or such condition is disturbed before Kitsap Transit directs the Contractor to proceed with the Work despite the condition, Kitsap Transit's right to address the changed conditions will be deemed to be prejudiced and the Contractor will be deemed to have waived any claim for extra compensation or extension of the Contract Time on account of any additional or different Work (including labor, materials and equipment) required because of such condition. Oral notice alone by the Contractor to Kitsap Transit, or the Engineer, regarding such condition shall not be adequate to avoid such waiver.
- (4) Upon receiving the Contractor's written notification, Kitsap Transit shall promptly investigate the worksite conditions and if the Project Manager determines that conditions exist which entitle the Contractor to an equitable adjustment in the Contract Amount to account for performance of the Work involved, and the additional Contract Time, if any, required to perform such Work, whether or not changed as a result of the conditions, then an adjustment, excluding loss of anticipated profits, will be made and the Contract modified in writing accordingly. The Engineer will notify the Contractor of his/her determination whether or not an adjustment of the Contract is warranted.
- (5) If Kitsap Transit determines, upon concurrence by the Engineer, that different site conditions do not exist and no adjustment in costs or time is warranted, such determination shall be final. If the parties are unable to agree on an equitable adjustment, Kitsap Transit may

nevertheless issue a Unilateral Change Order directing the Contractor to perform the changed Work pursuant to the paragraph below.

l) Contractor's Obligation to Proceed:

- (1) A request by Kitsap Transit, or the Engineer, to the Contractor for a change proposal shall not constitute authorization for the Contractor to proceed with any such proposed change in the Work, nor shall such request justify any delay in the performance of existing Work. Pending agreement on the terms and conditions of any Change Order in writing, Kitsap Transit, or the Engineer, may direct the Contractor to proceed immediately with the Work in question, in which event the Contractor shall promptly and diligently proceed with any changed Work, in accordance with the Contract Documents, so as to avoid delay and minimize any increase in the time required for performance of the Work. The Contractor shall keep daily records of the costs incurred in connection with such Work and submit daily timesheets to Kitsap Transit accordingly. The Engineer's action in approving timesheets submitted by the Contractor shall not be construed as acceptance of the Contractor's position regarding the need for the magnitude of an equitable adjustment for such Work. An inadvertent payment made by Kitsap Transit for Work not specifically authorized in writing by Kitsap Transit shall not constitute evidence or acknowledgement of Kitsap Transit's liability for such payment.
- (2) Subject to Sections 3.21 B and C above, no later than thirty (30) calendar days from the "Satisfactory Completion" of any additional Work, the Engineer shall prepare and issue to the Contractor either an agreed upon Bilateral Change Order or Unilateral Change Order, including any adjustment in the Contract Amount, Contract Time, or both. As used herein, "Satisfactory Completion" means that the Engineer shall have confirmed in writing that all tasks have been completed to the reasonable satisfaction of Kitsap Transit, including submittal by the Contractor of all required time and cost documentation. Satisfactory Completion does not mean Substantial Completion. In no event shall the Contractor proceed with any change in the Work until it has obtained a fully executed Change Order or written order or direction from the Engineer to proceed.

3.22 PROTEST PROCEDURE FOR CHANGE ORDERS

- A) The Contractor accepts all requirements of a Change Order by: 1) endorsing it, 2) writing a separate acceptance, or 3) not protesting in the way this Section provides. A Change Order that is not protested as provided in this Section shall be full payment and final settlement of all claims for Contract Time and for all costs of any kind, including but not limited to that for labor, materials, equipment, overhead, fee (profit), costs of delays, and damages (direct or indirect), or any other claim for damages of any kind or nature, if any, related to any Work either covered or affected by the change. By not protesting as this Section provides, the Contractor also waives any additional entitlement and accepts from the Engineer any written or oral order, including directions, instructions, interpretations, and determinations.
- B) If the Contractor disagrees with any of the terms of a Change Order, the Contractor shall give immediate oral notice of protest to the Engineer, prior to performing the Work, and shall submit a written protest within ten (10) calendar days of the Contractor's receipt of the Change Order. The protest shall identify the point of disagreement, those portions of the Contract Documents believed to be applicable, and an estimate of quantities and costs involved in the change. When protest of a Change Order relates to compensation, the Contractor shall keep full and complete records of the cost of such changed Work and shall permit Kitsap Transit to have access to those records as requested to enable Kitsap Transit to evaluate the merits of the protest.
- C) A protest shall not relieve the Contractor of its obligation to proceed without delay with the Work as directed in the Change Order. No adjustment to the Contract Amount or Contract Time will

be made on account of Work performed preceding the Contractor giving oral notice of protest to the Engineer to be followed by written protest as required herein.

- D) Within fourteen (14) calendar days of the Engineer's receipt of written notice above, the Contractor shall provide the following details:
- (1) A detailed factual statement of the claim for a change in the Contract Amount and Contract Time, if any, providing all necessary dates, locations and items of Work affected by the claim;
 - (2) The date on which facts arose which gave rise to the claim;
 - (3) The name of each employee or agent or consultant of Kitsap Transit knowledgeable about the claim;
 - (4) The specific provisions of the Contract Documents which supported the claim;
 - (5) The identification of any documents and the substance of any oral communications that support the claim;
 - (6) Copies of any identified documents, other than the Contract Documents, that support the claim;
 - (7) If an adjustment in Contract Time is sought, the specific days and dates for which it is sought; the specific reasons Contractor believes an extension in the Contract Time should be granted; and Contractor's analysis of its progress schedule to demonstrate the reason for the extension in Contract Time (time impact analysis);
 - (8) If an adjustment in the Contract Amount is sought, the exact amount sought and a breakdown of that amount; and
 - (9) A statement certifying, under penalty of perjury, that the claim as submitted is made in good faith, that the supporting cost and pricing data are true and accurate to the best of the Contractor's knowledge and belief, that the claim is fully supported by the accompanying data, and that the amount requested accurately reflects the adjustment in the Contract Amount or Contract Time for which the Contractor believes Kitsap Transit is liable. The individual signing such certification shall be a duly authorized representative of the Contractor who has the necessary and appropriate authority and responsibility to commit the Contractor to the truthfulness of the certification.
 - (10) A statement that the claim covers all changes in cost and in time (direct, indirect, impact, consequential, and otherwise) to which the Contractor and all subcontractors and suppliers of any tier are entitled.
- E) Kitsap Transit shall be entitled to recover its costs incurred for analysis/administration of processing and evaluating a claim to the extent a portion of the claim that is determined to be not recoverable from Kitsap Transit. The cost of reimbursement will be the percentage of the original claim that is determined to be not recoverable times the cost of analysis/administration.

3.23 FINAL INSPECTION

If the Contractor does not expeditiously proceed with correctional completion of the listed deficiencies identified in the Final Inspection, Kitsap Transit may, in its sole discretion, remove such items from the Scope of Work by Change Order. In such instance, Kitsap Transit may choose to: 1) have the Work performed by another Contractor with the cost of such Work to be deducted from the amount due the Contractor or claimed against the retained percentage, or 2) accept a credit for the uncompleted Work to be deleted by Change Order, with the amount of the credit to be negotiated between the parties. The costs incurred by Kitsap Transit to conduct re-inspections of uncompleted Punch List items may be offset from any monies due the Contractor. The rights provided Kitsap Transit under this Section shall not relieve the Contractor of its responsibilities as required under any other provisions of the Contract Documents.

3.24 FINAL COMPLETION AND FINAL ACCEPTANCE

- A) **Final Completion**: Shall mean final approval of the Project only in that the Contract Work has been physically performed, cleaned up, and completed in accordance with the Contract terms and conditions; however, the Contractor may still have Punch List items to complete and Record Documents, warranties and other documents to submit to Kitsap Transit.
- B) **Final Acceptance**: Shall mean that the Project is complete in accordance with the Contract Documents AND has been performed to the full satisfaction of Kitsap Transit. Acceptance shall not constitute acceptance of unauthorized or defective Work, material or equipment. Kitsap Transit shall not be barred by acceptance from requiring the Contractor to remove, replace, repair, or dispose of unauthorized or defective Work, material, or equipment or from recovering damages for same. A "*Certificate of Final Completion and Final Acceptance*" will be issued by Kitsap Transit provided that:
- ✓ The physical Work on the Project is complete and the Contractor has satisfactorily demobilized.
 - ✓ All temporary locks, keys or other items loaned or signed-out to the Contractor, Subcontractors, suppliers and vendors are returned to Kitsap Transit.
 - ✓ Project Record Documents, drawings, manuals, and warranties have been submitted to Kitsap Transit and approved by the Project Manager.
 - ✓ Outstanding claims are settled, or are identified in writing by the Contractor as unsettled at the time of application for Final Payment.
 - ✓ An invoice representing 95% payment of the Contract Amount, less any progress payments, has been requested.
 - ✓ Kitsap Transit's Project Manager approves Final Acceptance.
- C) The date of Final Acceptance further marks the start of the forty-five (45) day waiting period for any liens or claims against the Contractor's retainage before releasing the retained funds. Final Acceptance may not be given if any claims previously made in writing and identified by the Contractor, a Subcontractor, or material supplier remain unsettled at the time of the Contractor's application for Final Payment.
- D) Neither Final Completion nor Final Acceptance shall relieve the Contractor of the responsibility to indemnify, defend, and protect Kitsap Transit against any claim or loss resulting from the failure of the Contractor or its Subcontractors to pay all laborers, mechanics, Subcontractors, suppliers, or any industrial insurance and medical aid required under Title 51 RCW.

3.25 PROJECT CLOSEOUT

In addition to any Contract close-out requirements stated elsewhere in the Contract Documents, the Contractor shall submit to Kitsap Transit's Contracts Administrator, upon Final Acceptance of the Work, the following items:

- 1) An L&I approved "Affidavit of Wages Paid" for Prime and all Subcontractors.
- 2) An invoice representing 5% Final Payment for retainage.
- 3) Certificate of payment of State excise taxes, if applicable.
- 4) Release of any outstanding claims.

3.26 FORFEITURE OF CONTRACT

- A) Should the Contractor, at any time, refuse or neglect to supply a sufficiency of skilled workmen or of material of the proper quantity or quality, or fail in any respect to prosecute the Work with

promptness and diligence, or fail in the performance of any of the agreements herein contained, Kitsap Transit may, at its option, after giving ten (10) calendar days written notice to the Contractor, provide such sufficiency of labor and materials and deduct the cost thereof from any monies due or thereafter to become due under this Contract. In the event of such refusal, neglect, or failure, Kitsap Transit may, by written notice to the Contractor and its Surety or its representative, or if the Contractor abandons the Work undertaken under the Contract, Kitsap Transit may, at its option with such written notice to the Surety and without any written notice to the Contractor, transfer the employment of said Work from the Contractor to the Surety. Upon receipt of such notice, the Surety shall enter upon the premises and take possession of all materials, tools, and appliances thereon for the purpose of completing the Work included under this Contract, and employ by Contract or otherwise, any person or persons to finish the Work and provide the material therefore, without termination of the continuing full force and effect of the Contract.

- B) In case of such transfer of employment to the Surety, the Surety shall be paid in its own name on estimates covering the Work subsequently performed under the terms of the Contract and according to the terms hereof, without any right of the Contractor to make any claim for the same or any part thereof. In lieu of the foregoing, if Kitsap Transit so elects, it may terminate the employment of the Contractor for said Work and enter upon the premises and take possession of all materials, tools and equipment thereon for the purposes of completing the Work included under the Contract, and employ by Contract or otherwise, any person or persons to finish the Work and provide the materials therefore. In case of the discontinuance of employment by Kitsap Transit as aforesaid, the Contractor shall not be entitled to receive any further balance of the amount to be paid under this Contract until the Work shall have been fully finished. At this time, if the unpaid balance of the amount to be paid under this Contract exceeds the expense incurred by Kitsap Transit in finishing the Work, and all damages sustained or which may be sustained by Kitsap Transit by reason of such refusal, neglect, failure or discontinuance of employment, such excess shall be paid by Kitsap Transit to the Contractor. If such expense and damages shall exceed the unpaid balance, the Contractor and its Surety and each thereof shall be jointly and severally liable therefore to Kitsap Transit and shall pay the difference to Kitsap Transit.
- C) Notwithstanding the foregoing, Kitsap Transit, in the event of the Contractor's breach of the Contract, reserves the right to terminate the Contractor and exercise any and all remedies at law or in equity.

3.27 CLAIMS

- A) A "claim" is a demand or assertion by one of the parties seeking, as a matter of right, adjustment or interpretation of Contract terms, payment of money, and extension of time or other relief with respect to the terms of the Contract. All claims shall be made in writing. The responsibility to substantiate claims shall rest with the party making the claim.
- B) **Notice of Intent to Claim:** It is an express condition of the Contractor's right that to make a claim, or to receive any recovery or relief under or in connection with the Contract, the Contractor must submit a written "Notice of Intent to Claim" to Kitsap Transit within seven (7) calendar days of the Contractor having known of the event, or commencement of the event giving rise to the claim. If the event or occurrence is claimed to be an act of omission of Kitsap Transit, notice shall be given prior to the commencing of the portion of Work to which such alleged act or omission relates. The written "Notice of Intent to Claim" shall set forth: 1) the reasons for which Contractor believes additional compensation will or may be due; 2) the nature of the costs involved; 3) the Contractor's plan or action for mitigating such costs; and 4) if ascertainable, the amount of the potential claim.

- C) Failure to comply with the provisions hereof shall constitute a waiver by the Contractor of any right, equitable or otherwise, to bring any such claim against Kitsap Transit.
- D) **Written Claim:** Within ten (10) calendar days of Kitsap Transit's receipt of the written Notice of Intent to Claim, the Contractor shall provide Kitsap Transit, at a minimum, the following details:
- 1) The date and a detailed description of the event giving rise to the Claim;
 - 2) A detailed statement of the nature of all impacts to the Contractor and all others, if any, affected by the Claim event;
 - 3) A detailed breakdown and calculation of the amount of the adjustment in Contract Amount, if any, sought by the Contractor for itself and for others, if any, together with substantiation and backup for all costs;
 - 4) A detailed explanation of the amount of the adjustment to Contract Time, if any, sought by the Contractor, together with Critical Path Method (CPM) schedule analysis showing the claimed impact on the Project completion date asserted by the Contractor;
 - 5) A detailed analysis and substantiation for other relief, if any, sought with respect to the terms of the Contract; and
 - 6) A statement of all provisions of the Contract Documents upon which the Claim is based.
- E) The Contractor's failure to submit any claim in writing within the relevant time and in the manner prescribed shall waive any relief that might otherwise be due with respect to such claim. Pending final resolution of a Claim, the Contractor shall proceed diligently with performance of the Contract. Kitsap Transit will continue to make proper payments for Work items that are undisputed and in accordance with the Contract.
- F) The Contractor and Kitsap Transit acknowledge and agree that this Section has been specifically negotiated and they hereby waive all claims against each other for the following damages that may arise out of or relate to this Contract and Project, incurred by the Contractor (and those for whom the Contractor is responsible) for principal or home office expenses including, without limitation, the compensation of personnel stationed there, for losses of bonding capacity, and for loss of profit other than anticipated profits arising directly from Work performed.
- G) **Time and Schedule:** If the Contractor claims entitlement to an extension of time to complete the Project, it shall be the Contractor's responsibility to prove that the delay in completion of the Project was caused specifically by a delay in a portion of the Project that was on the critical path of the approved Progress Schedule. Each Claim must be submitted in writing no later than seven (7) calendar days after the delay occurs and shall be accompanied by a revised Progress Schedule reflecting the effects of the delay and Bids to minimize these effects. If no Progress Schedule has been submitted to Kitsap Transit reflecting conditions prior to delay for which relief is sought, then a Progress Schedule so reflecting these conditions shall be prepared and submitted with the Claim.
- H) **Additional Records and Audit:** The Contractor shall be responsible to furnish, when requested by Kitsap Transit, such further information and details as may be required to determine the facts or contentions involved in said Claim. The Contractor agrees to give Kitsap Transit access to account books, records or other materials relating to the Work and shall cause its Subcontractors to do the same so that Kitsap Transit can investigate such Claim. The right of audit shall continue throughout the claims and/or dispute processes described herein. Depending upon the grounds for relief and the nature of the relief sought, additional submittals and conditions upon submitting claims may be required, as set forth elsewhere in the Contract.
- I) **Review Timeframe:** Kitsap Transit shall be entitled to reasonable time, in no case more than thirty (30) calendar days, after it receives the written Claim accompanied by proper supporting

documents and evidence, in which to investigate, review and evaluate such Claim. When Kitsap Transit has completed its investigation, review, and evaluation, it will advise the Contractor of the relief, if any, to which it has found the Contractor to be entitled. Should the Contractor not be satisfied with Kitsap Transit's findings, the disputes resolution process outlined in the Contract may be used within fourteen (14) calendar days after being so advised thereof. The Contractor shall submit written notice of a dispute within this fourteen (14) day period. In no event shall claims be made after Final Payment is made under the Contract completion provisions. A claim will cease to be a claim if, at any time, a Change Order or Contract Amendment resolving the issue is signed by both parties.

3.28 AUDIT OF RECORDS

- A) Original accounting records and all other relevant records pertaining to the Work performed under this Contract by the Contractor shall be open to inspection and audit by representatives of Kitsap Transit during the Contract Time and for a period of not less than three (3) years after the date of Final Acceptance or Contract termination, and the Contractor shall retain such records for that period. Where payment for equipment, materials, labor or other incidentals thereto is based on the cost to parties other than the Contractor, the Contractor expressly guarantees that the records of such other parties shall be open to inspection and audit by representatives of Kitsap Transit on the same terms and conditions as the records of the Contractor.

- B) Kitsap Transit shall have the right to seek reimbursement of any amount it determines was overpaid to the Contractor. If an audit is to be commenced more than ninety(90) days after Final Acceptance, the Contractor will be given reasonable notice of the time when such audit is to begin. The Contractor agrees that no claim shall be made against Kitsap Transit for the Work described herein unless the Contractor makes available to Kitsap Transit all records to be maintained in accordance with this subparagraph.

END OF SECTION 3

INDEPENDENT CONTRACTOR AGREEMENT
CONTRACT NUMBER: KT XX-XXX

TITLE: {Title}

TERM: 12:01 a.m. PDT on Month Date, 20__ through 11:59 p.m. PDT on Month Date, 20__.

PARTIES: KITSAP TRANSIT

60 Washington Ave., Ste 200, Bremerton, WA 98337
Phone: 360-824-4941 / Fax: 360-377-7086

Contacts: , Project Manager –
, Payments & Invoicing –

CONSTRUCTION COMPANY (CONTRACTOR)

Address: _____
Phone: _____ / Fax: _____

THIS AGREEMENT is made and entered into this ____ day of Month, 20__ by and between the KITSAP TRANSIT SYSTEM, a Washington municipal corporation, hereinafter called "KITSAP TRANSIT", _____, hereinafter called the "CONTRACTOR".

In consideration of the terms and conditions contained herein, and attached and made a part of this Agreement, the parties hereto covenant and agree as follows:

- 1. Contract Documents: This Agreement; the Bid Documents for IFB # KT XX-XXX in its entirety, including the Plans, Appendices and any Attachments; Contractor's submitted Bid and any supplemental items, as accepted by Kitsap Transit; All Addenda issued prior to and all modifications issued after execution of this Contract; shall constitute the Contract Documents and are complementary. These form the Contract and all are as fully a part of the Contract as if attached to this Contract or repeated herein.
2. Performance: The Contractor shall diligently perform all Work and furnish all tools, materials, and equipment in accordance with and as described in the attached Bid Documents and Contract Drawings; and as directed shall perform any changes in the Work in accordance with the Contract Documents; and shall provide and bear the expense of all equipment, Work and labor, of any sort whatsoever that may be required for the transfer of materials and for constructing and completing the Work provided for in these Contract Documents, except any items mentioned therein to be furnished by Kitsap Transit.
3. Time of Performance: The Contractor shall commence the Work under this Contract effective upon receipt of a written Notice to Proceed and shall continue in good faith and effort to Final Completion status within NUMBER (XX) Working Days of said Notice.
4. Rate of Payment Shall Not Exceed \$ as set forth on the Contractor's Bid Form, attached herein by reference, unless a written Change Order is permitted pursuant to ARTICLE 6.00 hereunder and elsewhere in the Contract Documents. Kitsap Transit shall pay the Contractor in current U.S. funds subject to the terms, conditions, additions and deductions as provided in the Contract Documents.
5. The parties accept that this Agreement is the complete expression of the terms hereto and any oral representation or understandings not incorporated herein are excluded. Further, any modification of the Agreement shall be in writing and signed by both parties. Failure to comply with any of the provisions stated herein shall constitute material breach of Contract and cause for termination. The parties also agree that the forgiveness of the non-performance of any provision of this Agreement does not constitute a waiver of all other provisions of this Agreement. It is further provided that no liability shall attach to by reason of entering into this Contract, except as provided herein.

ARTICLE 1.00 ADDITIONS OR DELETIONS

Kitsap Transit reserves the right to add or delete items, agencies, or locations, as determined to be in its best interest, provided such items, agencies or locations are related to those on Contract and will not represent a significant increase or decrease in size or scope of the Contract. Such additions or deletions will be by mutual agreement, will be at prices consistent with the original Bid, and will be evidenced by issuance of a written Contract Amendment issued by Kitsap Transit in accordance with ARTICLE 6.00 below.

ARTICLE 2.00 ASSIGNMENT

The Contractor shall not assign its obligations, transfer any interest, or sublet the service provided under this Contract, or any part thereof, without prior written consent of Kitsap Transit nor shall it assign, by Power of Attorney or otherwise, any of the monies payable under this Contract unless by and with the like consent of Kitsap Transit. In the event consent is given by Kitsap Transit to permit subletting, no such consent shall be construed as making Kitsap Transit a party to such Subcontractor or assignee, or of subjecting Kitsap Transit to liability of any kind whatsoever, to any Subcontractor. No Subcontractor shall, under any circumstances, relieve the Contractor of its liability and obligation under this Contract and all transactions with Kitsap Transit shall be made through the Contractor.

ARTICLE 3.00 COMPLIANCE WITH LAWS AND REGULATIONS

- 3.01 General Requirement:** The Contractor will at all times, at its sole cost and expense, comply with all applicable Federal, State and local laws, ordinances, regulations, orders, and codes in regards to all matters of its business operation and to performance of the Work and services under this Contract.
- 3.02 Registration:** The laws of the State of Washington require that the Contractor must be registered in the State of Washington. Out-of-state corporations must secure authority from the Secretary of State to transact business in the State of Washington. Accordingly, before Kitsap Transit can enter into a Contract with an out-of-state or foreign corporation, such entity must comply with Washington's corporation laws. Information and application forms relative thereto may be obtained from the Corporations Division, Office of the Secretary of State, PO Box 40234, Olympia, Washington 98504. The Corporate Information Line is (360) 725-0377 or e-mail at corps@sos.wa.gov.
- 3.03 Licenses, Permits and Similar Authorizations:** The Contractor, at no expense to Kitsap Transit, shall secure and maintain in full force and effect during the term of this Contract all required licenses, permits, fees, bonds, inspection fees, and similar legal authorizations for performance and completion of the Contract Work. It is Contractor's sole responsibility to monitor and determine any changes or the enactment of any subsequent regulations for said fees, assessments, or charges and to immediately comply with all related requirements. If for any reason the Contractor's required licenses or certificates are terminated, suspended, revoked or in any manner modified from their status at the time this Contract becomes effective, the Contractor shall notify Kitsap Transit immediately of such condition in writing.
- 3.04 Taxes:** If applicable, the Contractor will be responsible for adding sales tax to amounts due under the Contract and making payment of sales tax to the State of Washington, as determined by the Washington State Department of Revenue. All other taxes required by statute or regulation are the sole responsibility of the Contractor. No adjustments will be made in the Contract Amount because of any misunderstanding by, or lack of knowledge of, the Contractor as to liability for, or the amount of, any taxes for which the Contractor is solely liable or responsible for by law, or under this Contract, or because of any increase in tax rates imposed by any federal, State or local government. No charge by Contractor shall be made for Federal Excise Tax and Kitsap Transit agrees to furnish the Contractor with an exemption certificate where appropriate.

3.05 Wage and Hours Laws: The Contractor shall comply with all applicable provisions of the Fair Labor Standards Act (FLSA) and all other legislation affecting its employees and the rules and regulations issued thereunder insofar as applicable to its employees and shall, at all times, save Kitsap Transit free, clear and harmless from all actions, claims and expenses arising out of said Act and rules and regulations that are or may be promulgated in connection herewith.

ARTICLE 4.00 CONFLICTS OF INTEREST, GIFTS AND CONTEMPORANEOUS EMPLOYMENT

4.01 Kitsap Transit employees, agents, officers and board members may not solicit or accept gratuities, gifts, favors, other special consideration or anything of economic value from any present or potential Contractor, Subcontractor, supplier, vendor, customer, client, or any individual or organization doing or seeking business with Kitsap Transit. Use of one's position in a manner that constitutes a real or apparent personal or organizational conflict of interest or personal gain is strictly prohibited (FTA Cir 9030.1D).

4.02 Current and Former Employees: No current or former employee of Kitsap Transit and their immediate family members, or agents, officers, and board members of Kitsap Transit, may Contract with, influence, advocate, advise, or consult with a third party about a Kitsap Transit transaction, or assist with preparation of Bids submitted to Kitsap Transit while employed by Kitsap Transit or after leaving Kitsap Transit's employment, if he/she was substantially involved in determining the Work to be done or process to be followed while a Kitsap Transit employee. It is unethical for any Kitsap Transit employee who is participating directly or indirectly in the procurement process to become or to be, while such a Kitsap Transit employee, the employee of any person contracting with Kitsap Transit.

4.03 Organizational Conflicts of Interest: An organizational conflict of interest is a situation in which, because of other activities, relationships, or Contracts, a Contractor or Subcontractor is unable, or potentially unable, to render impartial assistance or advice to Kitsap Transit; a Contractor's objectivity in performing the Contract Work is or might be otherwise impaired; or a Contractor has an unfair competitive advantage. Kitsap Transit will evaluate future procurements related to this Contract to determine if there is an organizational conflict of interest. If an organizational conflict of interest exists, Kitsap Transit may prohibit the Contractor and any of its Subcontractors from participating in such related procurements/projects.

ARTICLE 5.00 CONFLICT AND SEVERABILITY

5.01 In the event of conflict between the Bid Documents and the terms and conditions of the Contract, Kitsap Transit, in its sole authority, shall determine which requirement shall apply and be considered the legally binding requirement. In the event of conflict between the Contract Document in its entirety and applicable laws, codes, ordinances, or regulations, the most stringent or legally binding requirement shall govern and be considered a part of this Contract.

5.02 In the event that any provision, portion, or application of this Contract is held to be unenforceable or invalid by any court of competent jurisdiction, Kitsap Transit and the Contractor shall negotiate an equitable adjustment in the provision of this Contract with a view toward effecting the purpose of this Contract and the validity and enforceability of the remaining provisions, or portions of applications thereof, shall not be affected thereby. Any provision of the Contract Documents found to be prohibited by law shall be ineffective to the extent of such prohibition without invalidating the remainder of the Contract.

ARTICLE 6.00 CONTRACT MODIFICATIONS

6.01 No alterations or variances of any of the terms, conditions, delivery, price, quantities, or Specifications of this Contract shall be effective without written consent of Kitsap Transit. Oral changes, amendments or agreements are not permitted. When it is necessary to modify the Contract Documents, either Kitsap Transit or the Contractor may initiate a Change Request. If

any change causes an increase or decrease in the cost of, or the time required for, the performance of any part of the Work under this Contract, whether changed or not changed by any such order, an Equitable Adjustment shall be made in the Contract Price or Contract Time, or both, without invalidating any other portion of the Contract. Prior to becoming a Contract modification, all changes to the Contract must be prepared in writing and fully executed by both parties. Only Kitsap Transit's Contracts Administrator shall have the express, implied, or apparent authority to alter, amend, modify, add, or waive any section or condition of this Contract on behalf of Kitsap Transit.

- 6.02** The Contractor must assert its right to an adjustment under this clause by delivering a written Change Request to Kitsap Transit which states the general nature and monetary extent of the claim. Kitsap Transit may require additional supporting documents in order to perform a cost analysis to determine the validity and reasonableness of the claim. If Kitsap Transit requests a change, the Contractor shall submit to Kitsap Transit, within seven (7) days after Contractor's receipt of any change request, a detailed price schedule proposal for the Work or service to be performed and note any modifications of other Contract provisions that may be required as a result of the change. No claim by the Contractor for an Equitable Adjustment hereunder will be allowed for any costs incurred more than seven (7) days before the Contractor gives written notice.
- 6.03** Any change exceeding twenty-five percent (25%) of the Contract Amount is considered a "Cardinal Change" and will not be permitted. Failure to agree to any adjustment shall be a dispute concerning a question of fact within the meaning of the clause of this Contract titled "Disputes" (ARTICLE 10.00); however, nothing in this clause shall excuse the Contractor from proceeding with the Contract as changed.

ARTICLE 7.00 DELIVERY

All Work or services must be made at the applicable project site location in accordance with the Contract Documents and time frames outlined therein or otherwise agreed upon. The acceptance by Kitsap Transit of late performance with or without objection or reservation shall not waive the right to claim damage for such breach nor preclude Kitsap Transit from pursuing any other remedy provided herein, including termination, nor constitute a waiver of the requirements for the timely performance of any obligation remaining to be performed by the Contractor.

ARTICLE 8.00 DETERMINATION OF RESPONSIBILITY

Should the Contractor be determined to be in violation of Federal, State, or local laws or regulations, Kitsap Transit reserves the right to modify its initial determination of responsibility at the time of Award and take other action as determined appropriate, including but not limited to termination of the Contract.

ARTICLE 9.00 DEVIATION FROM CONTRACT

The Contractor shall not make any alterations or variation in or addition to or deviation or omission from the terms of this Contract without the prior written consent of Kitsap Transit.

ARTICLE 10.00 DISPUTES

- 10.01 Decision of the Executive Director:** Except for Bid protest, any dispute concerning a question of fact or arising in the performance under this Contract which is not resolved by agreement of the parties shall be decided in writing by Kitsap Transit's Executive Director. Claims include, without limitation, controversies arising under the Contract and those based upon breach of Contract, mistake, misrepresentation, or other cause for Contract modification or revision. The decision of the Executive Director shall be promptly issued in writing and shall be immediately mailed or otherwise furnished to the Contractor. The decision shall state the reason(s) for the decision reached, and shall inform the Contractor of its appeal rights stated below. The Executive Director's decision shall be final and conclusive unless, within seven (7) calendar days from the

date of receipt of the decision, the Contractor mails or otherwise delivers a written appeal in court of Kitsap County. If the Executive Director does not issue a written decision regarding any Contract controversy within seven (7) calendar days after the Contractor's written request for a final decision, or within such longer period as may be agreed upon between the parties, then the aggrieved party may proceed as if any adverse decision had been received. The Contractor's failure to timely submit a dispute against the Executive Director's decision shall waive any relief that might otherwise be due with respect to such dispute.

10.02 Performance During Dispute: Pending final resolution of a dispute, the Contractor shall proceed diligently with the performance of the Contract and in accordance with the Executive Director's decision.

10.03 Rights and Remedies: The duties and obligations imposed by the Contract Documents and the rights and remedies herein shall be in addition to and not a limitation of any duties, obligations, rights and remedies otherwise imposed or available by law. No action or failure to act by Kitsap Transit or the Contractor shall constitute a waiver of any right or duty afforded any of them under the Contract, nor shall any such action or failure to act constitute an approval of or acquiescence in any breach thereunder, except as may be specifically agreed in writing. All claims, counterclaims, disputes and other matters in question between Kitsap Transit and the Contractor arising out of or relating to this Contract or its breach will be decided by mediation if the parties mutually agree, or in a court of competent jurisdiction within Kitsap County, State of Washington. Either party may request in writing that a dispute be submitted to mediation. Absent an agreement to a mediator, the mediation shall be conducted by Judicial Dispute Resolution (JDR) located in Kitsap County, Washington. The parties shall be equally responsible for the cost of any mediation. Mediation is optional and neither party is compelled to participate.

10.04 This "dispute" clause does not preclude consideration of law questions in connection with decisions provided for in the paragraphs above; provided that nothing in this Contract shall be construed as making final the decision of any administrative official, representative, or board on a question of law.

ARTICLE 11.00 EMERGENCY, DISASTERS AND FORCE MAJEURE

11.01 Force Majeure Definition: The term "Force Majeure" means an occurrence that is beyond the control of the party affected and could not have been avoided by exercising reasonable diligence. Force Majeure shall include acts of nature, war, riots, strikes, fire, floods, epidemics, or other similar occurrences. Except for payment of sums due, neither party shall be liable to the other or deemed in default under this Contract if and to the extent that such party's performance of this Contract is prevented by reason of Force Majeure.

11.02 The following shall be in effect during major emergencies or disasters:

- The Contractor acknowledges that government agencies are procuring goods/services for benefit of the public and therefore agrees, in support of public good purposes, to consider these government customers as first priority and shall make a best effort to provide the requested goods/services in as timely a manner as practicable.
- The Contractor and Kitsap Transit agree that a major emergency or disaster includes, but is not limited to: storms, high winds, earthquakes, floods, hazardous material releases, transportation mishaps, loss of utilities, fires, terrorist activities or combinations of the above.
- In the event the Contractor is unable to meet the delivery requirements, or is prevented from making delivery to the requested location, due to circumstances beyond its reasonable control, the Contractor agrees to make such delivery as soon as practicable or shall immediately assist Kitsap Transit in whatever reasonable manner to gain access to such goods or services or offer limited substitutions for consideration.

11.03 Notification: If either party is delayed by Force Majeure, said party shall provide written notification to the other within forty-eight (48) hours. The notification shall provide evidence of the Force Majeure to the satisfaction of the other party. Such delay shall cease as soon as practicable and written notification of same shall be provided. The time of completion shall be extended by Contract modification for a period of time equal to the time that the results or effects of such delay prevented the delayed party from performing in accordance with this Contract.

11.04 Rights Reserved: Kitsap Transit reserves the right to cancel the Contract and/or purchase materials, equipment or services from the best available source during the time of Force Majeure and the Contractor shall have no recourse against Kitsap Transit.

ARTICLE 12.00 ENFORCEMENT COSTS

In the event of litigation between the Parties hereto, declaratory or otherwise, for the enforcement of this Contract, or as a result of this Contract in any way, the prevailing party shall be entitled to recover from the other party, its reasonable attorney's fees and other costs incurred in such action or proceeding. In the event that the Parties engage in arbitration, mediation or any other alternative dispute resolution (ADR) forum to resolve a dispute in lieu of litigation, both parties shall share equally in the cost of the ADR method, including cost of mediator or arbitrator. In addition, each party shall be responsible for its own attorneys' fees incurred as a result of the ADR method.

ARTICLE 13.00 ENGLISH LANGUAGE

All documentation and any other written, oral, or other communications required in the performance of the Contract shall be prepared using the English language as used throughout the U.S. If English is not the prevalent language used at the job site, a person fluently proficient in the other language(s) used and in English shall be available to the representative during all working hours for interpretation.

ARTICLE 14.00 ERRORS AND OMISSIONS

If, at any time during the performance of this Contract, the Contractor becomes aware of any errors, omissions, discrepancies and actual or potential problems between the Contract Documents and any Federal, State or local law, rule, or regulation, the Contractor shall give immediate written notice thereof to Kitsap Transit's Contracts Administrator. Until such written notification has been given and one business day has elapsed, any services performed by the Contractor after such discovery will be done at the Contractor's risk.

ARTICLE 15.00 INDEMNIFICATION, HOLD HARMLESS AND STATUS

To the maximum extent permitted by law, the Contractor shall defend, protect, indemnify and hold harmless Kitsap Transit, its officers, employees and agents from and against any and all claims, demands, suits, penalties and liability of any kind, including injuries to persons or damages to property, which arise out of or are due to any acts, errors, or omissions of the Contractor, or the Contractor's employees, agents, and representatives in performing Work and services under this Contract provided; however, that if such liability is caused by or results from the concurrent negligence of Kitsap Transit, its officers, employees and agents, and the Contractor, or its employees and agents, this provision shall be valid and enforceable only to the extent of the Contractor's negligence; and provided further, that nothing herein shall require the Contractor to hold harmless or defend Kitsap Transit, its officers, employees and agents from any claims arising from the sole negligence of Kitsap Transit, its officers, employees and agents. The sole obligation to defend includes the payment of all reasonable attorney's fees and costs of Kitsap Transit's defense of any claim, suit or action within the scope of this Section whether or not suit was instituted. The Contractor specifically waives any immunity under the Industrial Insurance Act and assumes all liability for actions brought by him/her or his/her employees against Kitsap Transit for injuries in the performance of this Contract. The Contractor represents that this waiver has been negotiated with Kitsap Transit. Kitsap Transit will give the Contractor prompt notice in writing of the institution of any suit or proceeding and permit the Contractor, through its counsel, to defend same and will give all needed

information, assistance and authority to enable the Contractor to do so. This Article does not modify any other articles regarding any other conditions as are elsewhere agreed to herein between the parties.

ARTICLE 16.00 INSPECTION AND REJECTION

16.01 Kitsap Transit's inspection of all materials, equipment or services upon delivery is for the sole purpose of identification and shall not be construed as Final Acceptance or as acceptance of the materials, equipment or services if such does not conform to contractual requirements. If there are any apparent defects in the materials, equipment or services at the time of delivery, Kitsap Transit will promptly notify the Contractor thereof. If there are defects detected post-delivery, Kitsap Transit will notify the Contractor with a description of such non-compliance. Within seven (7) days of receiving such written notification, the Contractor shall provide Kitsap Transit with a detailed written plan which indicates the time and methods needed to bring the Work in compliance with the Contract. Without limiting any other rights, Kitsap Transit may require the Contractor to: 1) repair or replace any or all of the damaged goods at Contractor's expense; 2) refund Kitsap Transit the full price paid for any or all of the damaged goods and accept the return of such damaged goods. If Kitsap Transit rejects the Contractor's written plan, the Contractor may be determined to be in material default of the Contract.

16.02 This procedure to remedy defects is not intended to limit or preclude any other remedies available to Kitsap Transit by law, including those available under the Uniform Commercial Code, Title 62A RCW. Acceptance by Kitsap Transit of unsatisfactory performance, with or without objection or reservation, shall not waive the right to claim damage for breach, or terminate the Contract, nor constitute a waiver of requirements for satisfactory performance of any obligation remaining to be performed by the Contractor.

ARTICLE 17.00 INSURANCE REQUIREMENTS

17.01 The Contractor, at its sole expense and for the duration of the Contract, will purchase and maintain all insurance described herein to protect Kitsap Transit against any and all claims for damages to persons or property arising under Contract performance, whether by reason of acts or omissions of the Contractor or anyone directly or indirectly employed by the Contractor, and shall hold Kitsap Transit harmless for any claims presented to it as a result of the Contractor's negligence. Policies shall be endorsed and will not be canceled, materially changed or altered without thirty (30) days prior written notice submitted to the Kitsap Transit Risk Manager. Any exclusion must be pre-approved by the Risk Manager.

17.02 Additional Insured Endorsement: Language such as the following will be used in the description area of the ACORD Certificate when referring to the "Contracting Agency": **"KITSAP TRANSIT, ITS OFFICERS, AGENTS, AND EMPLOYEES ARE NAMED ADDITIONAL INSURED AS RESPECTS TO CONTRACT # KT XX-XXX"**.

Additional Insured Endorsement: General Liability Insurance and Builder's Risk Insurance must state that Kitsap Transit will be specifically named additional insured(s) for all coverage provided by this policy of insurance and shall be fully and completely protected by this policy from all claims. Taking into account the Scope of Work and Services to be performed by a Subcontractor, the Contractor shall prudently determine whether, and in what amounts, each Subcontractor shall obtain and maintain public liability, professional liability, and any other insurance coverage. Any insurance required of Subcontractors shall, where appropriate and/or applicable, name Kitsap Transit as an additional insured. The Contractor and its insurers shall endorse the required insurance policy (ies) to waive their right of subrogation against Kitsap Transit. The Contractor and its insurers also waive their right of subrogation against Kitsap Transit for loss of its owned or leased property or property under its care, custody and control. No provision in this Section shall be construed to limit the liability of the Contractor for services not done in accordance with the Contract, or express or implied warranties. The Contractor's liability for the services shall extend as far as the appropriate periods of limitation provided by law and up to any legal limits. The

Contractor may obtain any combination of coverage or limits that effectively provides the same or better amounts and types of coverage as stipulated above, subject to review and approval by Kitsap Transit. The Contractor warrants that this Contract has been thoroughly reviewed by the Contractor's insurance agent(s)/broker(s), who have been instructed by Contractor to procure the insurance coverage required by this Contract.

- 17.03 Subcontractors:** The Contractor shall include all Subcontractors, regardless of tier, as insured under all insurance policies required herein, or shall furnish separate certificates of insurance and endorsements for each Subcontractor. Subcontractor providing their own coverage will also name Kitsap Transit as an Additional Insured on their General Liability insurance policies and such a copy will be provided to Kitsap Transit. Failure of Subcontractor(s) to comply with insurance requirements does not limit the Contractor's liability or responsibility.
- 17.04 Excess Liability:** Coverage in the minimum amounts set forth herein shall not be construed to relieve the Contractor from liability in excess of such limits. Nothing contained within the insurance requirements shall be deemed to limit the scope, application and/or limits of the coverage afforded, which coverage will apply to each insured to the full extent provided by the terms and conditions of the policy(s). Nothing contained with this provision shall affect and/or alter the application of any other provision contained with this Contract.
- 17.05 Cancellation:** In the event of cancellation, non-renewal, revocation, or other termination of any insurance coverage required by this Contract, the Contractor shall provide written notice of such to Kitsap Transit within one (1) business day of the Contractor's receipt of such notice.
- 17.06 Attorney Fees:** If a lawsuit in respect to this insurance provision ensues and the amount of the liability claimed exceeds the amount of insurance coverage, the Contractor shall authorize representatives of Kitsap Transit to collaborate with counsel for the insurance carrier, if any, in settling or defending such claim. The Contractor shall appear and defend that lawsuit at its own cost and expense, and if judgment is rendered or settlement made requiring payment of damages by Kitsap Transit, its officers, agents, and employees, the Contractor shall pay the same.
- 17.07 Failure of Coverage:** The Contractor's failure to fully comply with these insurance requirements during the term of the Contract shall be considered a material breach of Contract upon which Kitsap Transit may, after giving five (5) business days written notice to the Contractor to correct the breach, immediately terminate the Contract; or at its discretion, alternatively procure and maintain in the name of the Contractor and at the Contractor's sole expense, such types of insurance to the extent deemed proper up to the amount of the required coverage(s). Kitsap Transit may offset the cost of such insurance against payment due to the Contractor under the Contract. If Kitsap Transit is damaged by the failure of the Contractor to maintain any of these insurance requirements, or to so notify Kitsap Transit, then the Contractor shall bear all costs attributable thereto. Suspension or termination of this Contract shall not relieve the Contractor from its insurance obligations hereunder. Furthermore, the Contractor's failure to provide such insurance in a time frame acceptable to Kitsap Transit shall enable Kitsap Transit to suspend or terminate the Contractor's Work hereunder in accordance with Contract provisions regarding "Termination For Convenience/Default".
- 17.08 Rights of Subrogation:** Kitsap Transit reserves and retains its rights of subrogation and shall further have the right, at its election and expense, to pursue collection and recovery from any and all responsible third parties. The Contractor shall cooperate with Kitsap Transit in such recovery and collection, and shall make its records and personnel available. As to an accident or incident to which this paragraph is applicable, any and all sums so recovered by Kitsap Transit as provided hereunder, after deduction only of court costs, shall be reimbursed to the Contractor. The pendency of any collection efforts against third parties, including litigation, shall in no way delay or diminish the obligation of the Contractor to promptly remit the sums due to Kitsap Transit under the provisions of this subpart.

ARTICLE 18.00 JOINT VENTURE CONTRACTOR

In the event the Contractor is a joint venture of two or more Contractors or is comprised of more than one legal entity, each such entity shall be jointly and severally liable hereunder. All grants, covenants, provisos, claims, rights, powers, privileges, and liabilities of the Contract shall be construed and held to be severally and jointly. Any notice, order direction, request or other communications required to be or that may be given by Kitsap Transit to the Contractor under this Contract shall be well and sufficiently given to all persons being the Contractor if given to any one or more of such persons.

ARTICLE 19.00 JURISDICTION LAWS AND VENUE

This Contract shall be governed in all respects by the laws of the State of Washington and authorities having jurisdiction over the Contract Work will be deemed to be included in the Contract the same as though herein written out in full. The jurisdiction for any action hereunder shall be exclusively brought in the Superior Court for Kitsap County in the State of Washington.

ARTICLE 20.00 LIENS, CLAIMS AND ENCUMBRANCES

All materials, equipment, or services performed or delivered by the Contractor shall be free of all liens, claims, or encumbrances of any kind.

ARTICLE 21.00 NON-DISCRIMINATION

21.01 Kitsap Transit is an Equal Opportunity Employer. With respect to performance under this Contract, the Contractor shall take such action as may be required to ensure full compliance with Chapter 49.60 RCW, Discrimination and Title VI of the Civil Rights Act of 1964. The Contractor shall not discriminate against any client, employee, or applicant for employment or for services because of race, creed, color, national origin, marital status, sex, age, Vietnam-era veteran status, disabled veteran status, income level, or disability; or the presence of any sensory, mental or physical handicap except for a bona fide occupational qualification with regard to, but not limited to the following: Employment upgrading, demotion or transfer, recruitment or any recruitment advertising, layoffs or terminations, rates of pay or other forms of compensation, selection for training, rendition of services.

21.02 In all solicitations made by the Contractor for Work to be performed under subcontract, including procurements of goods or leases of equipment, each potential Subcontractor or supplier shall be notified by the Contractor of its obligations under this Contract and the regulations relative to non-discrimination. Said assignment or subcontract shall include appropriate safeguards against discrimination, unless exempt by the regulations or directives issued pursuant thereto. In the event of breach of any of the above non-discrimination covenants, Kitsap Transit shall have the right to terminate the Contract and hold the same as if said Contract had never been made or issued. Furthermore, Kitsap Transit may bar the Contractor from performing any services for Kitsap Transit now, or in the future, unless a showing is made satisfactorily to Kitsap Transit that discriminatory practices have terminated and that recurrence of such action is unlikely.

ARTICLE 22.00 OWNERSHIP OF DOCUMENTS

All documents, data, drawings, Specifications, software applications and other products or materials produced by the Contractor in connection with this Contract shall be the property of Kitsap Transit. All such documents, products and materials shall be forwarded to Kitsap Transit at its request and may be used by Kitsap Transit as it sees fit. The Contractor shall preserve the confidentiality of all Kitsap Transit documents and data accessed for use in the Contractor's Work product.

ARTICLE 23.00 PAYMENT

23.01 All payments under this Contract are considered reimbursement for goods delivered and services rendered. **Pre-payments are not permitted.** If applicable, the Contractor and its Subcontractors shall have a business license with the City having jurisdiction over the Contract Work prior to any

Work beginning under the Contract. Failure to provide proof of a business license may delay payment of invoices.

- 23.02 Payment:** Except for retainage, payment will be made by Kitsap Transit to the Contractor within thirty (30) days after acceptance and approval of invoices by the Kitsap Transit Project Manager, *providing* a Labor and Industries approved “Statement of Intent to Pay Prevailing Wages” is received by Kitsap Transit for the Contractor and every Subcontractor who performed under the Contract *and* Certified Payrolls have been received within the specified time. Acceptance of such payment by the Contractor shall constitute full compensation for all supervision, labor, supplies, materials, Work, equipment and the use thereof, and for all other necessary expenses, incurred by the Contractor for the time period specified on the invoice.
- 23.03 Prompt Payment of Subcontractors:** The Contractor, as the Prime Contractor, is required to make payment to Subcontractors within thirty (30) days from the receipt of each payment it receives from Kitsap Transit for satisfactorily completed Subcontractor Work, whether such payment is a progress or final payment. The Contractor further agrees to return any retainage payments to each Subcontractor within thirty (30) days after the Subcontractor’s Work is satisfactorily completed. If payment disputes arise between the Contractor and Subcontractors, such disputes shall be resolved promptly through mediation or arbitration in order to prevent injury to Small Business Subcontractors. The Contractor shall specify in its subcontract agreements the dispute resolution method to be used. In addition, the Contractor will not be paid for Subcontractors’ Work unless it can show that a prompt payment method for Subcontractors is in place. The Contractor shall be required to provide copies of the Subcontracts to Kitsap Transit showing inclusion of these provisions, especially the Federal clauses. Kitsap Transit may withhold the applicable sum due a Subcontractor for non-compliance with this Section.
- 23.04 Approval of Invoices:** Prior to approval of payment, the Kitsap Transit Project Manager shall make verification of Work performed. Payment shall be based upon the Contractor’s prices submitted on the Bid Form, except as may be modified by written Change Order, or on a separate written quotation for a specific aspect of individual jobs or items.
- 23.05 Pay Requests:** A request for payment is to be submitted with detailed documentation of the Work completed, labor performed, and materials furnished in accordance with the Contract and shall represent the value of the Work completed less any lawful deductions such as retainage, tax or as otherwise authorized. Each pay request must contain the following minimum information: 1) Contract Number; 2) Date of invoice; 3) Invoice number; 4) Quantity, unit measure, unit price and item description, as appropriate; 5) Total price for invoice; and 6) sales tax as a separate line item, if applicable. The Contractor must ensure that all paperwork associated with a particular invoice references the same identifying number. For example, Work Orders, receiving documents, delivery tickets, etc. and the final invoice must all bear a corresponding number that links the paperwork together. Failure to comply with this requirement may delay payment.
- 23.06 Invoices shall be submitted to:** Kitsap Transit, Accounts Payable, 60 Washington Ave., Suite 200, Bremerton, WA 98337 for all transactions made during a calendar month by the 5th day of the following month.
- 23.07 Final Payment:** A final application for payment shall be prepared upon completion of the Work, satisfaction of any test requirements, and fulfillment of the Contract. Retainage will be administered in accordance with RCW 60.28 as outlined elsewhere in the Contract provisions.
- 23.08 Payment does not imply acceptance of Work:** The granting of any progress payment or payments by Kitsap Transit, or the receipt thereof by the Contractor, shall not constitute in any sense acceptance of the Work or a waiver of Kitsap Transit’s right to reject defective or non-conforming Work, materials, or equipment, even though the same is covered by the payment, nor is it a waiver of any other rights of Kitsap Transit and shall in no way lessen the liability of the

Contractor to remedy defective Work, materials, equipment or service which does not conform to the Contract Documents, though the character of such Work may not have been apparent or detected at the time such payment was made. Materials, components, or service not conforming to the instructions or the Contract requirements will be rejected and shall be replaced or remedied by the Contractor without delay. Payments due and unpaid in accordance with the Contract Documents shall bear interest as specified in RCW 39.76.

ARTICLE 24.00 PERFORMANCE STANDARDS

- 24.01** The word *service(s)*, as used in this clause, includes services performed, craftsmanship, and materials or products furnished or used in performing services. The Contractor shall comply with recognized quality industry service standards as applicable. All references to standards, whether for delivery of goods, processes, assemblies, craftsmanship, performance, or similar purposes shall mean, unless otherwise noted, the most recent available published version of such standard. When reference is made to standards, the standards are to be made a part of this Contract and to have the same effect as if fully reproduced herein.
- 24.02** If at any time during the performance of this Contract the Contractor becomes aware of actual or potential problems, fault or defect in the project or any non-conformance with any Contract Document, Federal, State, or local law, rule, or regulation, the Contractor shall give immediate written notice thereof to Kitsap Transit's Contracts Administrator.
- 24.03** In the case of an emergency where Kitsap Transit believes delay could cause serious injury, loss or damage, Kitsap Transit may waive the written notice and either direct the Contractor correct the defect or correct the defect of its own accord. In either case, the Contractor is responsible for all costs of remedying the defect and Kitsap Transit will charge-back the cost for such repairs to the Contractor, including freight, regardless of who actually corrects the defect.
- 24.04** **Non-Performance of Services:** If any unsatisfactory condition or deficiency is detected, or if any of the services performed do not conform to the Contract requirements, Kitsap Transit shall give written notice to the Contractor and request that the Work be performed again in conformity with the Contract. The Contractor shall, within twenty-four (24) hours of receiving such notice, immediately facilitate the Work to repair the condition, correct the defect, error, or non-conformity to the satisfaction of the Kitsap Transit Project Manager, or designee, and at no additional cost to Kitsap Transit.
- 24.05** If the Contractor fails to initiate any corrective action procedure after receiving the first notification of unsatisfactory performance, Kitsap Transit reserves the right to dispatch a third party Contractor, or use Force Account through use of Kitsap Transit employees at a rate equal to the employee's hourly rate plus administrative costs, to perform or otherwise resolve any unacceptable Work or scope of service. The Contractor is responsible for all incurred costs, including freight, to resolve the documented issues performed by a third party Contractor or Kitsap Transit personnel. Kitsap Transit will deduct such costs from any balance due, or which may become due, to the Contractor or charge-back the cost to the Contractor regardless of who actually corrects the defect.
- 24.06** After the first occurrence of any non-performance, Kitsap Transit may send a "Notice of Non-Performance" to the Contractor detailing the exact nature of non-performance, remaining Work to be performed, and the date of non-performance. The Contractor shall acknowledge and respond to the Notice within three (3) business days of receipt and shall promptly proceed to remedy the situation described therein to Kitsap Transit's satisfaction. Receipt of notice is evidenced upon signature of certified mail return receipt or three business (3) days after mailing.
- 24.07** Continued non-performance may result in Contract termination. A further finding of non-responsibility may be determined and any future bids by the Contractor for Kitsap Transit

Contracts may be rejected without consideration. Kitsap Transit may also recommend the Contractor be removed from any Small Works Roster. Acceptance by Kitsap Transit of unsatisfactory performance, with or without objection or reservation, shall not waive the right to claim damage for breach, or terminate the Contract, nor constitute a waiver of requirements for satisfactory performance of any obligation remaining to be performed by the Contractor.

ARTICLE 25.00 PROPERTY LIABILITY

Unless otherwise provided for, the Contractor assumes the risk of, and shall be responsible for, any loss or damage to Kitsap Transit furnished property in its possession, or in the possession of any agents or employees of the Contractor, resulting from the Contractor's negligent or willful misconduct, except for reasonable wear and tear in the normal performance of this Contract. The Contractor shall bear no liability for any negligent acts or abuse of property by Kitsap Transit.

ARTICLE 26.00 RELATIONSHIP OF THE PARTIES – INDEPENDENT CONTRACTOR

- 26.01** The Contractor is, and shall be considered at all times during the term of this Contract, an independent Contractor whereby the parties will be acting in their individual, corporate or governmental capacities and not as agents, employees, partners, joint ventures, or associates of one another. The Contractor shall not make any claim of right, privilege or benefit which would accrue to an employee of Kitsap Transit under Chapter 41.06 Revised Code of Washington (RCW) or Title 51 RCW.
- 26.02** The Contractor will be solely and entirely responsible for its acts and for the acts of its agents, employees, servants, Subcontractors or representatives during the performance of this Contract. The implementation of all services and the authority to control and direct the performance of the details of the Work lies solely with the discretion of the Contractor; however, the results of the Work contemplated herein must meet Kitsap Transit's approval and shall be subject to Kitsap Transit's general rights of inspection and review to secure the satisfactory completion thereof.
- 26.03** Any and all claims that may or might arise under the Workers' Compensation Act on behalf of said employees or other persons while so engaged, and any and all claims made by a third party as a consequence of any act or omission on the part of the Contractor's employees or other persons while so engaged on any of the Work or services provided to be rendered herein, shall be the sole obligation and responsibility of the Contractor.
- 26.04** The Contractor shall indemnify and hold harmless Kitsap Transit from and against any and all costs (including attorney fees incurred in defense) or liabilities (including payroll taxes, penalties or interest) arising out of any breach of the above representations and warranties or any assertions that the Contractor is not an independent Contractor.
- 26.05** Upon Contract execution ("Effective Date"), the Contractor agrees that it has a business account established with the Washington State Department of Revenue, and other State agencies as required by the particular case, for the payment of all State taxes normally paid by employers and businesses, and has registered for and received a Unified Business Identifier (UBI) number from the State of Washington.

ARTICLE 27.00 REPRESENTATIVES

- 27.01** **Kitsap Transit Representatives.** The Contracts Administrator is Kitsap Transit's designated representative for Contract compliance. Kitsap Transit's Project Manager is the designated primary representative for performance compliance. Both are listed on the front page of this Contract. The Engineer is the designated A&E Consultant ("Engineer") performing Construction Management and secondary Project Management on behalf of Kitsap Transit. Kitsap Transit designates Company's Name, Full Name, P.E. as its Resident Engineer.

27.02 Contractor Representative. The Contractor shall appoint a representative as the Contract liaison agent through whom Kitsap Transit will communicate with the Contractor. The Contractor shall respond to all written communications from Kitsap Transit representatives within seven (7) calendar days from receipt.

27.03 Either party shall have the right to change any representative or address it may have given to the other party by giving such other party due notice in writing of such change.

ARTICLE 28.00 RISK OF LOSS AND TITLE

Regardless of FOB point, the Contractor agrees to bear all risks of loss, injury, or destruction of goods and materials ordered herein which occur before delivery and acceptance. Such loss, injury, or destruction shall not release the Contractor from any obligation hereunder.

ARTICLE 29.00 SERVICE OF NOTICES

All notices, statements, demands, requests, consents, approvals, authorizations, offers, agreements, appointments, or designations desired or required to be given under this Contract by either party to the other shall be promptly made in writing and shall be sufficiently given if served upon the party to receive the same or if sent by certified mail, return receipt requested, postage prepaid, and addressed to the office of such representative as stated in this Contract, or to such other address as either party may hereafter designate in writing. Notice sent by mail shall be deemed to have been given three (3) calendar days after proper mailing. The Contractor agrees to provide copies of any notices given Kitsap Transit to such other persons or entities as Kitsap Transit may require from time to time.

ARTICLE 30.00 STATE AND LOCAL LAW DISCLAIMER

In the event that any provision, portion, or application of this Contract is held to be unenforceable or invalid by any court of competent jurisdiction, Kitsap Transit and the Contractor shall negotiate an equitable adjustment in the provision of this Contract with a view toward effecting the purpose of this Contract and the validity and enforceability of the remaining provisions, or portions of applications thereof, shall not be affected thereby.

ARTICLE 31.00 SUGGESTIONS TO CONTRACTOR

Any plan or method of Work suggested to the Contractor by Kitsap Transit, but not specified or required in writing under the Contract, if adopted or followed by the Contractor in whole or part, shall be used at the risk and responsibility of the Contractor and Kitsap Transit shall assume no responsibility therefore.

ARTICLE 32.00 SUPERVISION AND COORDINATION

The Contractor shall: 1) Competently and efficiently, supervise and direct the implementation and completion of all Contract requirements specified herein; 2) Designate a representative for the Work under this Contract to which all communications given by Kitsap Transit to the representative or shall be binding on the Contractor.

ARTICLE 33.00 SUSPENSION OF CONTRACT

Kitsap Transit may at any time and without cause suspend the Contract or any portion thereof for a period of not more than thirty (30) calendar days by written notice to the Contractor. Kitsap Transit will not be liable for any additional travel costs incurred by the Contractor while the Work is suspended. The Contractor shall resume performance within fifteen (15) calendar days of written notice from Kitsap Transit.

ARTICLE 34.00 TERMINATION

34.01 Termination for Convenience. Kitsap Transit may terminate this Contract, in whole or in part, at any time by written notice to the Contractor when it is in Kitsap Transit's best interest. After receipt of a written Notice of Termination, and except as directed by Kitsap Transit, the Contractor shall

immediately stop Work as directed in the Notice and comply with all other requirements in the Notice. The Contractor shall be paid its costs on only that portion of the Work satisfactorily performed up to the date of termination as specified in the Notice. The Contractor shall promptly submit its termination claim to Kitsap Transit, together with detailed supporting documentation, to be paid to the Contractor. If the Contractor has any property in its possession belonging to Kitsap Transit, the Contractor will account for the same, and dispose of it in the manner Kitsap Transit directs.

34.02 Termination for Default. If the Contractor does not deliver supplies in accordance with the Contract delivery schedule, or fails to prosecute the Work or any separable part with the diligence that will ensure completion within the time specified in this Contract or any extension, or fails to complete the Work within this time, or if the Contractor fails to comply with any other provision of this Contract, Kitsap Transit may terminate this Contract for default. Termination shall be effected by Kitsap Transit serving a Notice of Termination on the Contractor specifying the nature of the default and the effective date of termination. In this event, Kitsap Transit may assume the Work and complete it by Contract or otherwise, and may take possession of and use any materials, equipment, and facilities on the Work site necessary for completing the Work. The Contractor and its Sureties shall be liable for any damage to Kitsap Transit resulting from the Contractor's refusal or failure to complete the Work within the specified time, whether or not the Contractor's right to proceed with the Work is terminated. This liability includes any increased costs incurred by Kitsap Transit in completing the Work. The Contractor will only be paid the Contract Price for supplies delivered and accepted, or on only that portion of the Work satisfactorily performed in accordance with the manner of performance set forth in the Contract, less any damages to Kitsap Transit caused by such default, up to the date of termination as specified in the Notice. If the Contractor has any property in its possession belonging to Kitsap Transit, the Contractor will account for the same and dispose of it in the manner Kitsap Transit directs. The Contractor's right to proceed shall not be terminated nor the Contractor charged with damages under this clause if:

- 1) The delay in completing the Work arises from unforeseeable causes beyond the control and without the fault or negligence of the Contractor. Examples of such causes include: acts of God, acts of Kitsap Transit, acts of another Contractor in the performance of a Contract with Kitsap Transit, epidemics, quarantine restrictions, strikes, freight embargoes; and
- 2) The Contractor, within ten (10) calendar days from the beginning of any delay, notifies Kitsap Transit in writing of the causes of delay. If in the judgment of Kitsap Transit the delay is excusable, the time for completing the Work shall be extended. The judgment of Kitsap Transit shall be final and conclusive on the parties, but subject to appeal under the Disputes clause.

If, after termination of the Contractor's right to proceed, it is determined that the Contractor was not in default, or that the delay was excusable, the rights and obligations of the parties will be the same as if the termination had been issued for the convenience of Kitsap Transit.

34.03 Opportunity to Cure. Kitsap Transit in its sole discretion may, in the case of a termination for breach or default, allow the Contractor ten (10) calendar days in which to cure the defect. In such case, the Notice of Termination will state the time period in which cure is permitted and other appropriate conditions. If the Contractor fails to remedy to Kitsap Transit's satisfaction the breach or default or any of the terms, covenants, or conditions of this Contract within ten (10) calendar days after receipt by the Contractor of written notice from Kitsap Transit setting forth the nature of said breach or default, Kitsap Transit shall have the right to terminate the Contract without any further obligation to the Contractor. Any such termination for default shall not in any way operate to preclude Kitsap Transit from also pursuing all available remedies against the Contractor and its Sureties for said breach or default.

34.04 Waiver of Remedies for any Breach. In the event that Kitsap Transit elects to waive its remedies for any breach by the Contractor of any covenant, term or condition of this Contract, such waiver by Kitsap Transit shall not limit Kitsap Transit 's remedies for any succeeding breach of that or of any other term, covenant, or condition of this Contract.

ARTICLE 35.00 WAIVER OF RIGHTS BY KITSAP TRANSIT

Kitsap Transit shall be deemed to have waived a right or remedy only if issued or confirmed in writing as a waiver by Kitsap Transit. No waiver of one right or remedy shall act as a waiver of any other right or remedy or as a subsequent waiver of the same right and remedy.

ARTICLE 36.00 WARRANTY OF TITLE

36.01 The Contractor shall have no property right in the materials and equipment used after they have been attached or affixed to the Work or existing real property, or after any payment has been made by Kitsap Transit towards the value of materials delivered to the site of the Work, or stored subject to or under the control of Kitsap Transit. Title to all such materials shall become the property of Kitsap Transit upon being so attached or affixed, or after any payment towards the value of materials stored off site or delivered to the site of the Work, or stored subject to or under the control of Kitsap Transit, whichever occurs earlier.

36.02 No material, supplies, equipment, or items for the Work shall be purchased subject to any chattel mortgage or under a conditional sale or other agreement by which an interest therein, or in any part thereof, is retained by the seller or supplier. The Contractor shall warrant good title to all materials, supplies, equipment, and items installed or incorporated in the Work and are free from any claims, liens, or charges. Neither the Contractor, nor any person, firm, nor corporation furnishing any material or labor for any Work covered by this Contract shall have any right to lien upon any improvement or appurtenance thereon. This Article shall not defeat or impair the right of the persons furnishing materials or labor to recover under any Payment Bond given by the Contractor for their protection, or any rights under State law permitting such persons to look to retained funds due the Contractor in the hands of Kitsap Transit.

36.03 The provisions of this Article shall be inserted or referenced in, or otherwise made a part of all subcontracts and material Contracts, and notice of its provisions shall be given to all persons furnishing materials for the Work whenever no formal Contract is entered into for such materials. Additionally, as part of the subcontract, material Contract, or notice, the Contractor shall provide to such Subcontractors and suppliers the name, address, and phone number of the Contractor's bonding company and the bond number applicable to the Contract under which the Subcontractor or supplier would make its claim.

END OF SECTION 4

PART 1 – INSTRUCTIONS

All entries below shall be legible and entered in ink or typed. Do not leave an item blank or your Bid may be considered non-responsive. Mark spaces that do not apply to your firm with the initials "N/A" (Not Applicable).

PART 2 – CONTRACTOR INFORMATION

Business Name, as registered: _____

Type of Business (sole proprietorship, partnership, corporation, other) _____

Name & Title of person preparing Bid: _____

Mailing Address, including Zip Code: _____

Physical Address, including Zip Code: _____

Telephone/Fax Numbers, including Area Code: Ph: _____ Fax: _____

E-mail Address: _____

Federal Tax Identification Number: _____

WA State Contractor Registration Number: _____

WA Unified Business Identification (UBI) Number: _____

WA Industrial Insurance Account Identification Number: _____

WA Employment Security Dept. Number: _____

WA State Excise Tax Registration Number: _____

DBE / OMWBE / MBE / SDB Certification Number(s): _____

Dunns Registration Number: _____

PART 3 – RECEIPT OF ADDENDA

3.1 FAILURE TO ACKNOWLEDGE RECEIPT OF ADDENDA MAY RESULT IN YOUR BID BEING CONSIDERED NON-RESPONSIVE.

3.2 Receipt of the following Addenda is acknowledged:

Addendum No.: _____ Received By: _____ Date: _____

Addendum No.: _____ Received By: _____ Date: _____

Addendum No.: _____ Received By: _____ Date: _____

Addendum No.: _____ Received By: _____ Date: _____

3.3 No Addenda Received _____ (initial)

PART 4 – BIDDER’S CERTIFICATION AND GUARANTEE

4.1 I/WE CERTIFY, that to the best of my/our knowledge and belief that I/we fully understand:

- ❖ The nature of the Work and the goal of the Project;
- ❖ The instructions and requirements of the Contract Documents;
- ❖ The terms and conditions of the Contract Documents;
- ❖ That all costs are included this Bid;
- ❖ That the information contained in this Bid is accurate and complete;
- ❖ The offer shall be kept open for a period of ninety (90) days from the Bid Due Date;
- ❖ That I/we have the legal authority to commit this company to a contractual agreement;
- ❖ That final funding is based upon budget amounts approved by the Kitsap Transit Board of Directors.
- ❖ That the submitted Bid will become part of the public record.

4.2 I/WE GUARANTEE to complete the Work within sixty (60) Calendar Days following receipt of a Notice to Proceed, should I/We be the successful Bidder.

Authorized Signature

Date

Printed Name & Title: _____

Company Name: _____

PART 5: Schedule of Values:

Having carefully examined all documents for this Project, as well as the site of the Work, and the availability of materials and labor we, the above signed Bidder, propose to perform all Work identified herein in strict compliance with the Specifications, Plans, terms and conditions contained within the Contract Documents for the amounts set forth below:

Kitsap Transit KT 21-730- M/V Reliance Engine Replacement and Rebuild

Description	Unit	Unit Qty.	Unit Price	Extended Price
Docking	LS	1	\$	\$
Removal of Port Engines	LS	1	\$	\$
Removal of Starboard Engines	LS	1	\$	\$
Installation of Owner Supplied Engines	LS	1	\$	\$
Major Overhaul of Removed Engines	EA	4	\$	\$
Installation of Rebuilt Engines	LS	1	\$	\$
Delivery of (2) rebuilt Engines to Bremerton	LS	1	\$	\$
Sea Trials	LS	1	\$	\$
			Base Total	\$

*This is the Award Amount that will be used to determine low Bidder. Kitsap Transit, at its sole discretion, will award optional work based on available funds.

NON-COLLUSION

The Bidder affirms that, in connection with this Bid, the prices or cost data have been arrived at independently, without consultation, communication, or agreement for the purpose of restricting competition and that the proposal herewith submitted is a genuine and not a sham or collusive Bid, or made in the interest or on behalf of any person not therein named; and further says that the said Bidder has not directly, or indirectly, induced or solicited any Bidder on the above Work or supplies to put a sham Proposal, or any other person or corporation to refrain from Bidding; and that said Bidder has not in any manner sought by collusion to secure to himself/herself an advantage over any other Bidders.

CONFLICTS OF INTEREST & ANTI-KICKBACKS

In regards to any performance of the Work or the provision of services or materials under the Contract resulting from this solicitation the Bidder affirms that:

1. It has no direct or indirect pecuniary or proprietary interest, and that it shall not acquire any such interest, which conflicts in any manner or degree with the services required to be performed under this Contract and that it shall not employ any person or agent having such interest. In the event that the Bidder, as Contractor, or its agents, employees or representatives hereafter acquires such a conflict of interest, it shall immediately disclose such interest to Kitsap Transit and take immediate action to eliminate the conflict or to withdraw from said Contract as Kitsap Transit may require.
2. No officer, employee, Board member, agent of Kitsap Transit, or family member of same shall have or acquire any personal interest in this submittal, or have solicited, accepted or granted a present or future gift, favor, service, or other thing of value from or to any person involved in this submittal and that no such gratuities were offered or given by the Bidder or any of its agents, employees or representatives, to any official, member or employee of Kitsap Transit or other governmental agency with a view toward securing a Contract or securing favorable treatment with respect to the awarding or amending, or the making of any determination with respect to the Award or performance of this Contract.

CONTINGENT FEES AND GRATUITIES

The Bidder affirms that in connection with this Bid:

1. No person or selling agency, except bona fide employees or designated agents or representatives of the Bidder, has been employed or retained to solicit or secure this Contract with an agreement or understanding that a commission, percentage, brokerage, or contingent fee would be paid.
2. No gratuities, in the form of entertainment, gifts or otherwise, were offered or given by the Contractor or any of its agents, employees or representatives, to any official, member or employee of Kitsap Transit or other governmental agency with a view toward securing this Contract or securing favorable treatment with respect to the awarding or amending, or the making of any determination with respect to the performance of this Contract.

SEGREGATED FACILITIES

The Bidder certifies that their company does not and will not maintain or provide for their employees any segregated facilities at any of their establishments, and that they do not and will not permit their employees to perform their services at any location under its control where segregated facilities are maintained. The Bidder agrees that a breach of this certification will be a violation of the Equal Opportunity or Civil Rights clause in any Contract resulting from acceptance of this Bid. As used in this Certification, the term "segregated facilities" means any waiting rooms, Work areas, restrooms and washrooms, restaurants and other eating areas, parking lots, drinking fountains, recreation or entertainment areas, transportation, and housing facilities provided for employees which are segregated

by explicit directive or are in fact segregated on the basis of race, color, religion or national origin because of habit, local custom, or otherwise.

DEBARMENT AND SUSPENSION

The Bidder certifies to the best of its knowledge and belief that it and its principals:

1. Are not presently debarred, suspended, proposed for debarment, declared ineligible, or voluntarily excluded from covered transactions by any Federal department or agency;
2. Have not within a three (3) year period preceding this Bid been convicted of, or had a civil judgment rendered against them for, commission of fraud or a criminal offense in connection with obtaining, attempting to obtain or performing a public (Federal, State or local) transaction or Contract under a public transaction; violation of Federal or State antitrust statutes or commission of embezzlement, theft, forgery, bribery, falsification or destruction of records, making false statements or receiving stolen property;
3. Are not presently indicted for or otherwise criminally or civilly charged by a governmental entity (Federal, State or local) with commission of any of the offenses enumerated in Paragraph 2 above; and
4. Have not within a three (3) year period preceding this Bid had one or more public transactions (Federal, State or local) terminated for cause or default.

If Bidder is unable to certify to any of the statements in this certification, the Bidder shall attach an explanation to this Section.

Note: The penalty for making false statements in offers is described in 18 U.S.C. 1001.

THE BIDDER CERTIFIES OR AFFIRMS THE TRUTHFULNESS AND ACCURACY OF THE CONTENTS OF THE STATEMENTS SUBMITTED ON OR WITH THIS CERTIFICATION AND UNDERSTANDS THAT THE PROVISIONS OF 31 USC SECTIONS 3802, ET SEQ., ARE APPLICABLE THERETO.

Authorized Signature

Date

Printed Name & Title _____

Company Name _____

Subscribed and sworn to before me this _____ day of _____, 2021.

Notary Public in and for the State of _____, residing in _____

Signature: _____

****THIS FORM MUST BE NOTARIZED AND SUBMITTED WITH YOUR BID****

KNOW ALL MEN BY THESE PRESENTS, That we,

_____,
as PRINCIPAL and _____,
a corporation duly organized under the laws of the State of _____, and authorized
to do business in the State of Washington, as SURETY, are held and firmly bound unto the KITSAP
TRANSIT SYSTEM, as OBLIGEE, in the full and penal sum of five percent (5%) of the total amount of
the Bid Proposal of said PRINCIPAL for the Work hereinafter described, for the payment of which, well
and truly to be made, we bind our heirs, executors, administrators and assigns, and successors and
assigns, jointly and severally by these presents.

The condition of this bond is such, that whereas the PRINCIPAL is herewith submitting its sealed
Proposal for the following construction, to wit:

M/V RELIANCE ENGINE REPLACEMENT AND REBUILD # KT 21-730

said Bid and Proposal, by reference thereto, being made a part hereof.

NOW, THEREFORE, If the said Proposal Bid by the PRINCIPAL be accepted, and the Contract be
awarded to said PRINCIPAL, and if said PRINCIPAL shall duly make and enter into and execute said
Contract and shall furnish bonds as required by the OBLIGEE within a period of twenty (20) days from
and after said Award, exclusive of the day of such Award, then this bond shall be null and void, otherwise
it shall remain and be in full force and effect. Alternatively, if the PRINCIPAL, after submitting a Bid for
the above named project, is awarded the Contract and fails to provide bonds acceptable to the
OBLIGEE, the PRINCIPAL shall forfeit to the OBLIGEE and pay the penal amount of the Bid Deposit.

IN TESTIMONY WHEREOF, The PRINCIPAL and SURETY have caused these presents to be signed
and sealed this _____ day of _____, 20__

By _____
Principal

By _____
Surety

Contractor Name

**** THIS FORM MUST BE SUBMITTED WITH YOUR BID ****

Subcontractor List (To be SIGNED and submitted with the BID)

Prepared in Compliance with RCW 39.30.060 as amended.

If no Subcontractor is listed below, the Proposer acknowledges that it does not intend to use any Subcontractor to perform items **of Work over 10% of project cost.**

Subcontractor Name: _____

Work to be
Performed: _____

Subcontractor Name: _____

Work to be
Performed: _____

Subcontractor Name: _____

Work to be
Performed: _____

Signature: _____

KITSAP TRANSIT

INVITATION FOR BIDS # KT 21-730

FOR

M/V RELIANCE ENGINE REPLACEMENT AND REBUILD

EXHIBIT A

SCOPE OF WORK AND SPECIFICATIONS

Kitsap Transit is seeking bids from qualified sources to provide all labor, materials, tools, equipment, transportation, supplies, and incidentals required to complete all Work for the items included in the solicitation. The intent of the Contract is to prescribe a complete Work. Omissions from the Contract of details of Work that are necessary to carry out the intent of the Contract shall not relieve the Contractor from performing the omitted Work. All Work shall comply with all local, state, federal, regulations and industry standards; all of which are incorporated herein by reference as if they were written in their entirety.

Scope of Work:

MAIN ENGINE REPLACEMENT AND OVERHAUL

1 General Scope

The Contractor shall remove two (2) each main engines in the port engine room and two (2) each main engines in the starboard engine room. Two (2) of the main engines will be replaced with Owner Furnished spares. The other two (2) engines will be replaced with existing after the completion of a major overhaul. Overhauls of existing engines (4 total) shall be completed by an OEM authorized service representative.

2 References

- 2.1 DWG T24F181-100-001, General Arrangement
- 2.2 DWG T24F181-200-001, Machinery Arrangement Rev A
- 2.3 DWG T24F181-250-001, Main Engine Exhaust Rev A

3 Owner Furnished Material

- 3.1 2 EA – Caterpillar C18 ACERT Tier III Main Diesel Engines

4 Scope of Work

4.1 Owner Supplied Spare Engines

- 4.1.1 Owner will provide transportation of the spare engines from the Owner's facility to the Contractor's facility. All other transportation within this work specification will be arranged and carried out by the Contractor.

4.2 Preparations

- 4.2.1 Contractor shall disconnect all services to each main engine, including, but not limited to, fuel service, lube oil service, exhaust, raw water, engine controls, and electrical connections.
- 4.2.2 Contractor shall remove all interferences, ceiling tiles and insulation in way of the removal hatches as required to remove the main engines from the space.
- 4.2.3 Contractor shall remove the main engine removal hatches in the main deck and upper deck.

- 4.2.3.1 Contractor shall note there are three (3) each engine removal hatches per side of the vessel, see Reference 2.1 for guidance.

4.3 Removals

- 4.3.1 Contractor shall provide crane and rigging services to remove the main engines from the vessel.

4.4 Servicing

- 4.4.1 Contractor shall solicit an OEM approved service facility to perform the recommended major overhaul of each engine (4 engines total).
- 4.4.2 A Condition Found Report shall be provided to the Owner upon initial inspection of each engine.
- 4.4.3 At the completion of all work the Contractor shall provide the Owner with a detailed Service Report which shall include all work performed on each engine.
- 4.4.4 At the completion of the engine overhauls the Contractor will arrange transportation for two (2) of the main engines back to their facility. Owner will arrange transportation for the two (2) spares to be delivered to Kitsap Transit.

4.5 Installations

- 4.5.1 Contractor shall install the two (2) Owner furnished main engines.
- 4.5.2 Contractor shall install two (2) of the existing engines at the completion of the major overhaul.
- 4.5.3 Contractor shall provide all crane and rigging services to install and secure each engine into their respective engine rooms.
- 4.5.4 Contractor shall carry out an engine alignment on each of the four (4) main engines.
- 4.5.5 At the completion of a successful engine alignment the Contractor shall reconnect all services that were removed in Section 4.2.1.
- 4.5.6 Contractor shall reinstall all interferences that were removed in Section 4.2.2.
 - 4.5.6.1 Reinstallation of engine removal hatches shall be covered under a separate item.
- 4.5.7 Contractor shall replace all overhead insulation in the port and starboard main engine rooms with new to match existing.
 - 4.5.7.1 Existing insulation shall be removed under section 4.2.2 of this work specification.

4.6 Testing and Certification

- 4.6.1 Once all installations have been completed the Contractor shall perform pierside testing of each engine covered under this work specification.
 - 4.6.1.1 Testing shall verify that each engine is operating properly with no systems leaks, excessive vibration, etc.
- 4.6.2 A sea trail will be completed by the Owner prior to acceptance of the vessel.

Engine Removal Hatches

1 General Scope

The Contractor shall install each engine removal hatch that was removed in the work specification for Main Engine Replacement and Overhaul. Contractor shall make all necessary repairs to the port aft engine removal hatch.

2 References

2.1 DWG T24F181-100-001, General Arrangement

3 Owner Furnished Material

3.1 None

4 **Scope of Work**

4.1 Port/Starboard Forward Main/Upper Deck and Starboard Aft Engine Removal Hatches (5 Total Hatches)

4.1.1 Contractor shall prep all areas in way of the sealing surfaces prior to installation.

4.1.2 Contractor shall install the port and starboard forward main deck hatches, the port and starboard upper deck hatches, and the starboard aft main deck engine removal hatches with all new gaskets, sealant, and hardware.

4.1.3 Contractor shall conduct an air test to ensure the hatch covers are properly sealed.

4.2 Port Aft Engine Removal Hatch

4.2.1 Contractor shall prep all areas in way of the sealing surfaces prior to installation.

4.2.1.1 Owner is currently experiencing a great deal of flex and subsequent leaking of water in this area due to the configuration of passenger loading. Contractor shall inspect the sealing surfaces for any cracks, defects, etc.

4.2.1.2 Condition Found Report shall be provided to the owner on any deficiencies that are identified.

4.2.2 Contractor shall install the port aft engine removal hatch with all new gaskets, sealant, and hardware.

4.2.3 Contractor shall conduct an air test to ensure the hatch cover is properly sealed.

4.3 Disturbed Areas

4.3.1 Contractor shall be responsible for correcting any disturbed paint that occurs from the removal and reinstallation of the engine removal hatches.

KITSAP TRANSIT
INVITATION FOR BIDS # KT 21-730
FOR
M/V RELIANCE ENGINE REPLACEMENT AND REBUILD

EXHIBIT B
SUPPLEMENTAL BIDDER
RESPONSIBILITY CRITERIA
DOCUMENTATION STATEMENTS

DOCUMENTATION STATEMENTS

*** THIS EXHIBIT SHALL ONLY SUBMITTED WITH YOUR BID***

Criterion 2.30(E) – Public Bidding Crime

Statement of Bidder certifying it has not been convicted of a crime:

I, _____ an authorized representative of _____, a Bidder on this Project known as MV Reliance Engine Replacement and Rebuild KT 21-730, do hereby certify and swear under penalty of perjury that _____ has not been convicted of a crime involving bidding on Public Works Contracts within five (5) years from the Bid submittal date on this Project.

Subscribed and sworn to this _____ of _____, 20__.

Company

Authorized Representative

Title

Criterion 2.30(F) – Termination for Cause or Default

Statement of Bidder certifying it has not been terminated for cause or default:

I, _____ an authorized representative of _____, a Bidder on this Project known as, MV Reliance Engine Replacement and Rebuild KT 21-730 do hereby certify and swear under penalty of perjury that _____ has not had a government Public Works Contract terminated for cause by a government agency within five (5) years from the Bid submittal date on this Project.

Subscribed and sworn to this _____ of _____, 20__.

Company

Authorized Representative

Title

KITSAP TRANSIT

INVITATION FOR BIDS # KT 21-730

FOR

**M/V RELIANCE ENGINE REPLACEMENT AND
REBUILD**

EXHIBIT C

Certification of Compliance with Wage Payment Statutes

60 Washington Ave. Ste. 200
Bremerton, WA 98337
Phone: 360.479.6962
Fax: 360.377.7086

www.kitsaptransit.org



Certification of Compliance with Wage Payment Statutes

The bidder hereby certifies that, within the three-year period immediately preceding the bid solicitation date _____, the bidder is not a “willful” violator, as defined in RCW 49.48.082, of any provision of chapters 49.46, 49.48, or 49.52 RCW, as determined by a final and binding citation and notice of assessment issued by the Department of Labor and Industries or through a civil judgment entered by a court of limited or general jurisdiction.

I certify under penalty of perjury under the laws of the State of Washington that the foregoing is true and correct.

Bidder’s Business Name

Signature of Authorized Official*

Printed Name

Title

Date

City

State

Check One:

Sole Proprietorship Partnership Joint Venture Corporation

State of Incorporation, or if not a corporation, State where business entity was formed:

If a co-partnership, give firm name under which business is transacted:

** If a corporation, proposal must be executed in the corporate name by the president or vice-president (or any other corporate officer accompanied by evidence of authority to sign). If a co-partnership, proposal must be executed by a partner.*

KITSAP TRANSIT
INVITATION FOR BIDS # KT 21-730
FOR
M/V RELIANCE ENGINE REPLACEMENT AND
REBUILD
ATTACHMENT A
REFERENCE DRAWINGS

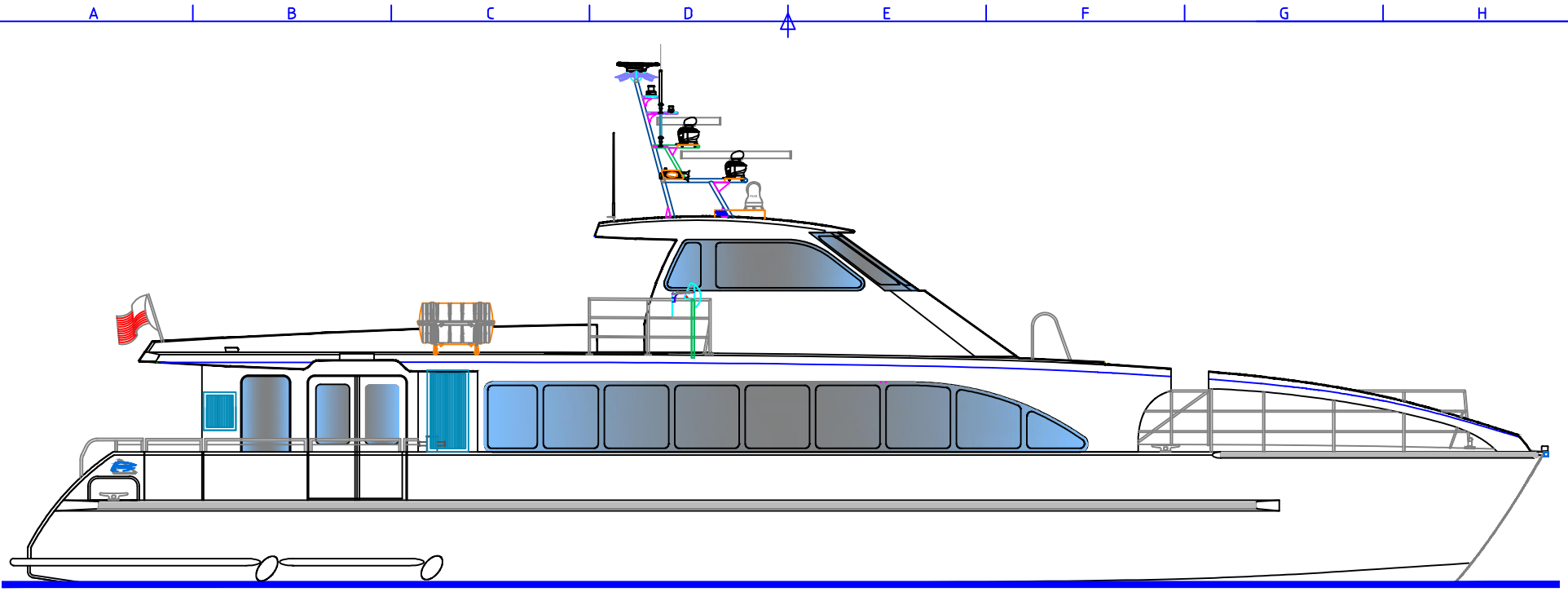

Outboard Profile

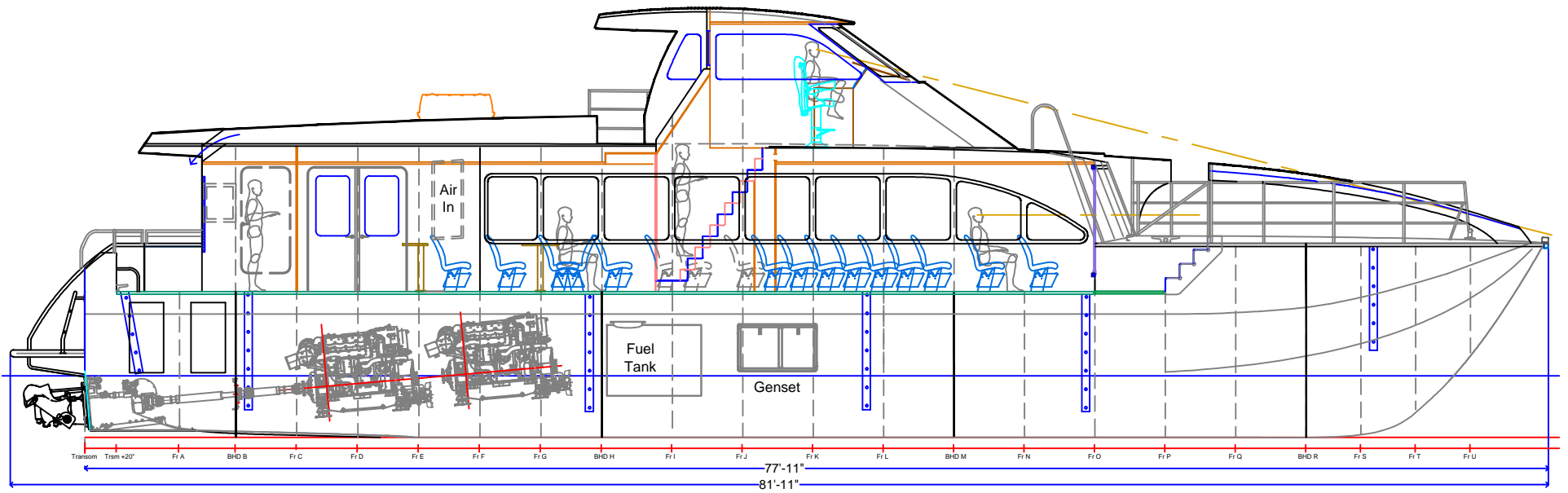

Inboard Profile

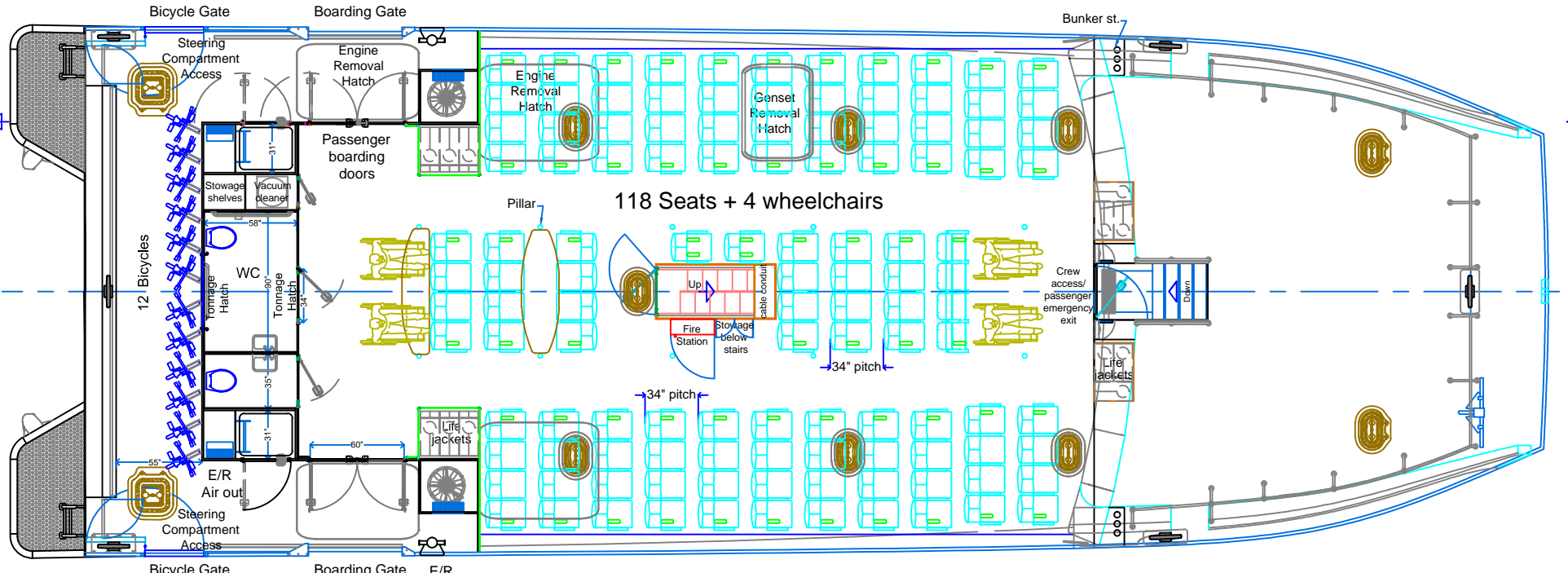

Main Deck Arrangement

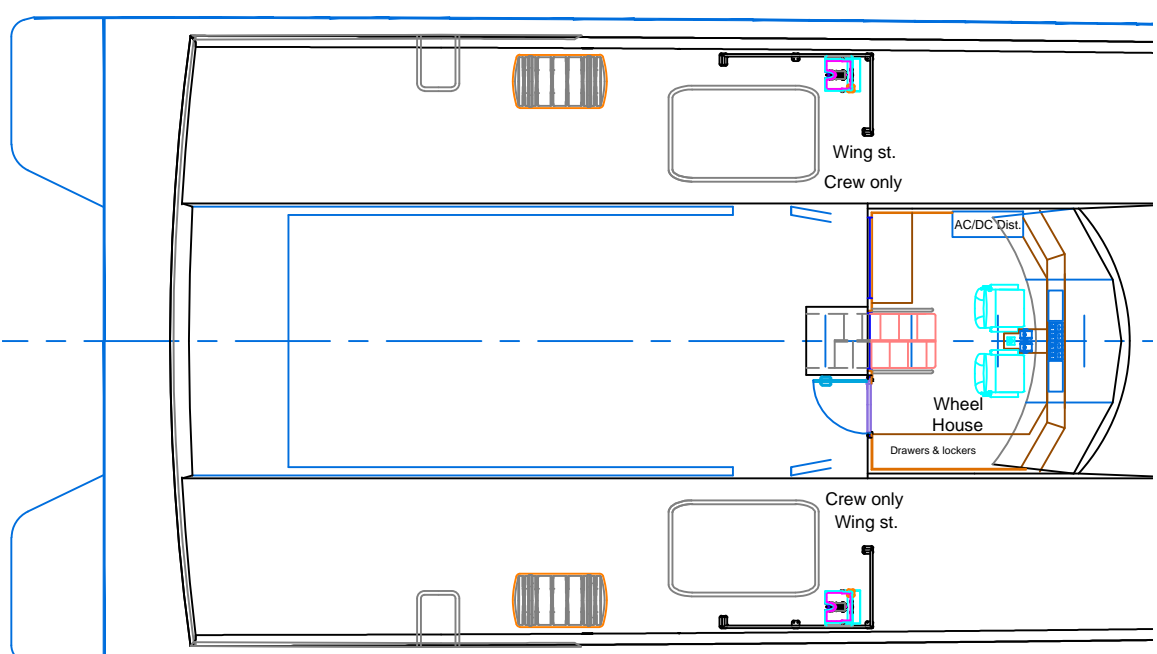

Upper Deck Arrangement

LEADING PARTICULARS	
Length (Demi-hull)	77.3 ft
Beam (Moulded)	28 ft
Engines (4)	Caterpillar C18 ACERT
Rating	803 bhp/2100 rpm
Propulsion	HJ 403 Waterjet
Service Speed	34-37 kn
Passengers	118
Builder	All American Marine
Hull Construction	High Strength Aluminium
Survey	USCG, Subch. T



Teknicraft Design
 PO Box 160, Beachlands
 Auckland 2147, New Zealand
 design@teknicraft.com
 www.teknicraft.com

PROJECT: 78' Low Wake Catamaran-Rich Passage 2&3

TITLE: General Arrangement

DRAWING No: T24F181-100-001	REV: A	SCALE: 1:100	PLOT SIZE: 11x17
---------------------------------------	------------------	------------------------	----------------------------

CONFIDENTIAL

PROPRIETARY INFORMATION
 THIS DOCUMENT IS PROPRIETARY! NO DATA OR DESIGN SHALL BE COPIED, REPRODUCED, DISCLOSED OR SUBMITTED TO ANY THIRD PARTY, OR USED FOR CONSTRUCTION OR MANUFACTURE WHOLE OR IN PART, OF ANY PRODUCT WITHOUT PRIOR APPROVAL AND WRITTEN CONSENT FROM TEKNICRAFT DESIGN LTD, NEW ZEALAND

Rev	Date	Description	Init.	Checked
A	12 May 19	As-Built Updates	SK	NDW
-	13 Mar 18	Issued for Reference	MAR	NDW

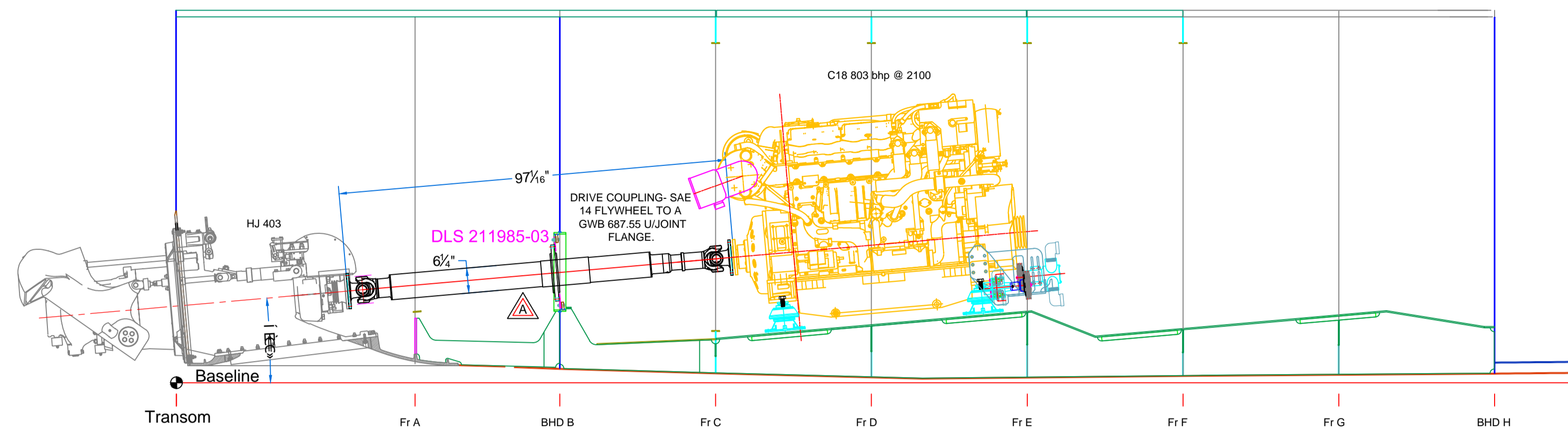

PROFILE-SHORT SHAFT LINE

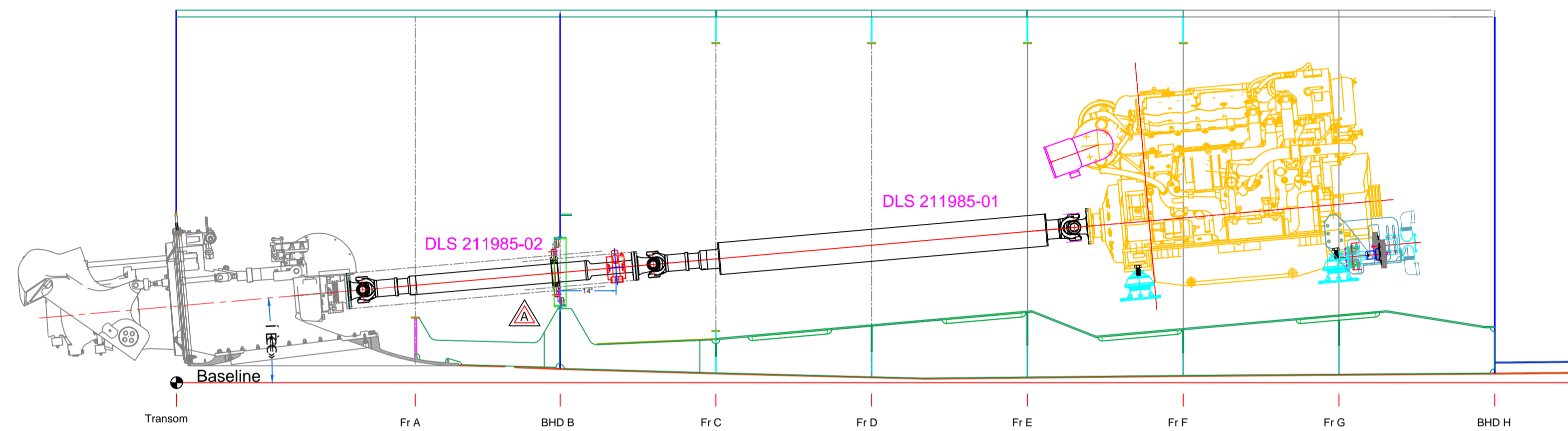

PROFILE-LONG SHAFT LINE

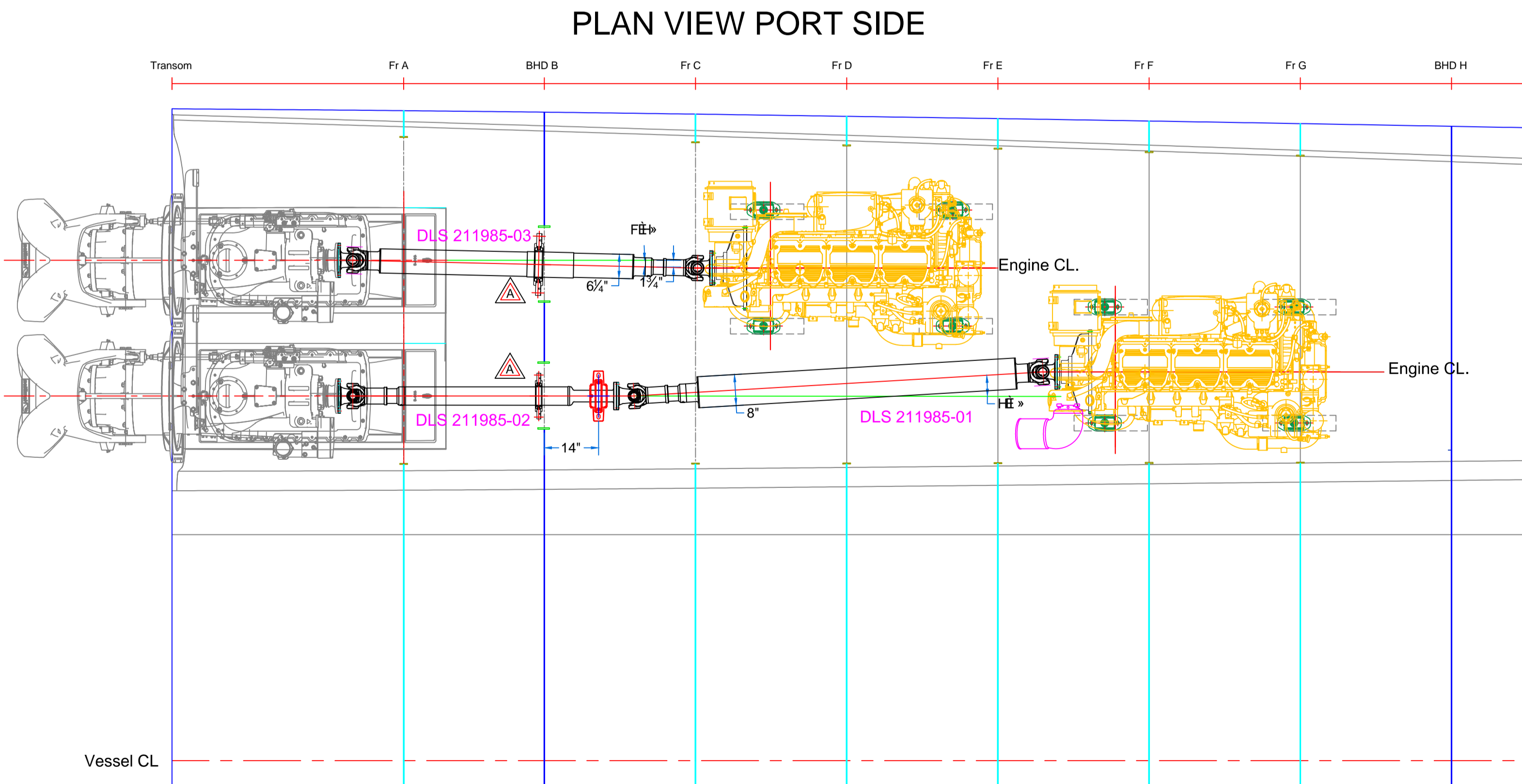

PLAN VIEW PORT SIDE

Physical Properties			
	Mass	Moment of Inertia	Torsional Stiffness
Waterjet-shaft	63.5 kg	0.06 kg.m ²	
Waterjet-coupling	9.4 kg	0.05 kg.m ²	
Waterjet-impeller	38.5 kg	0.54 kg.m ²	
DLS 211985-01	68 kg	0.3 kg.m ²	5.77E+04 Nm/rad
DLS 211985-02	66 kg	0.17 kg.m ²	2.28E+05 Nm/rad
DLS 211985-03	65 kg	0.24 kg.m ²	7.20E+04 Nm/rad

Driveshaft Specification					
Shaft #	Universal joint series	Operating length inch	Flange (in/out) mm	Tube Ø inch	Operating angle
DLS 211985-01	GWB 687.55	113.875	225/180	8.00	3.4 ± 0.25°
DLS 211985-02	GWB 687.55	71.75	180/225	4.75	0 ± 0.25°
DLS 211985-03	GWB 687.55	96.5	225/225	6.50	1.3 ± 0.25°

NOTE: Driveshafts to be balanced to a G-16 balance grade at 2500 rpm

- Notes:
- Shaft lengths shown is normal operating length between flange faces.
 - Engine speed must be electronically limited to no more than 2300 rpm to prevent possible overspeed of driveshaft under no load conditions.

Engine	Caterpillar C18 ACERT T3
Rating	599 kW/2100 rpm
Max rpm	2119 rpm calculated
Coupling	Vulkan- ISS-VKE-4911S/1/14/180
Shaft	GWB 687.55
Waterjet	Hamilton HJ403
Impeller	Type 63 kW

Teknicraft Design Ltd
PO Box 160, Beachlands
Auckland, New Zealand
Tel: +64 9 536 5070
design@teknicraft.com
www.teknicraft.com

PROJECT: 24m Catamaran - Rich Passage 2 & 3
TITLE: Driveline Arrangement

DRAWING No: T24F181-200-001	REV: A	SCALE: 1/2"=1'	PLOT SIZE: A1	USCG: TBD	Hull Number: TD24-53AA TD24-54AA
APPROVAL STATUS:	USCG Sistership	Rev.-	TEKNICRAFT: Checked	Rev. A	Unless otherwise stated: • All dimensions in inches • General tolerance ± 1/16" & ± 1 degree

CONFIDENTIAL

THIS DOCUMENT IS PROPRIETARY! NO DATA OR DESIGN SHALL BE COPIED, REPRODUCED, DISCLOSED OR SUBMITTED TO ANY THIRD PARTY, OR USED FOR CONSTRUCTION OR MANUFACTURE WHOLE OR IN PART, OF ANY PRODUCT WITHOUT PRIOR APPROVAL AND WRITTEN CONSENT FROM TEKNICRAFT DESIGN LTD, NEW ZEALAND

A	08 Dec 18	Moved Seal to Aft Side of BHD	GQ	-
-	02 Oct 18	Issued for Construction	CL	NDW
Rev	Date	Description	Init.	Checked

1. ALL DIMENSIONS IN INCHES UNLESS OTHERWISE STATED
2. DIMENSIONS ARE REFERENCE ONLY AND NOT TOLERANCED
3. SHAFT TO BE BALANCED TO ISO 1940/1 G16
4. LUBRICATE UNIVERSAL JOINTS EVERY 500 HOURS OF OPERATION
5. USE GRADE 2 NLGI LITHIUM SOAP BASED GREASE
EXAMPLE: CHEVRON ULTRA DUTY - EP

REVISIONS				
BY	REV	DESCRIPTION	DATE	APPROVED
JAV	-	INITIAL RELEASE	06/26/18	JFU

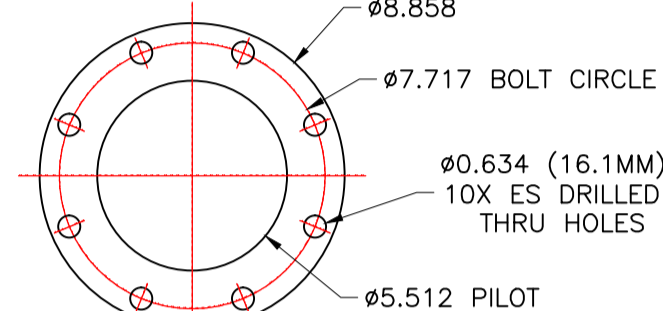
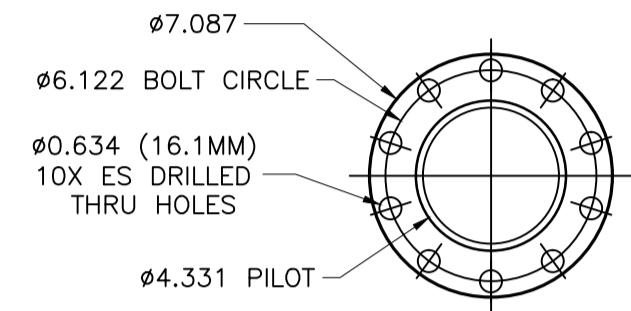
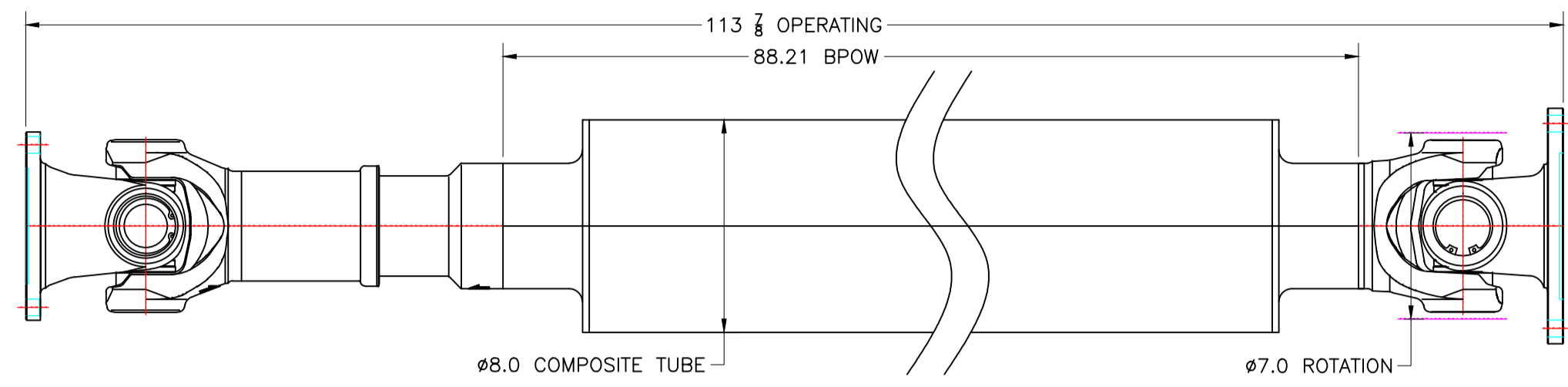

APPROVED FOR MANUFACTURE
SIGN _____
DATE _____

DRIVELINE SERVICE OF PORTLAND, INC. Telephone 503-289-2264 Toll Free 800-227-8608 www.driveshafts.com 9041 N.E. Vancouver Way Portland, Oregon 97211		THE INFORMATION CONTAINED HEREIN IS THE PROPRIETARY DATA OF DRIVELINE SERVICE OF PORTLAND AND IS NOT FOR DISSEMINATION OR DISCLOSURE IN WHOLE OR IN PART, FOR ANY PURPOSE OTHER THAN THAT FOR WHICH IT IS SUBMITTED EXCEPT AS AUTHORIZED IN WRITING BY DRIVELINE SERVICE OF PORTLAND.	
MFR. / MODEL		GWB 68755 WITH CARBON FIBER TUBE	
CUSTOMER		ALL AMERICAN MARINE	
APPLICATION		RICH PASSAGE II & III	
SIZE	CAGE NO.	DWG NO.	REV
A	ON1C1	211985-01	-
SCALE	NONE	DRAWN BY	JAV 06/26/18 SHEET 1 OF 1

1. ALL DIMENSIONS IN INCHES UNLESS OTHERWISE STATED
2. DIMENSIONS ARE REFERENCE ONLY AND NOT TOLERANCED
3. SHAFT TO BE BALANCED TO ISO 1940/1 G16
4. LUBRICATE UNIVERSAL JOINTS EVERY 500 HOURS OF OPERATION
5. USE GRADE 2 NLGI LITHIUM SOAP BASED GREASE
EXAMPLE: CHEVRON ULTRA DUTY - EP

REVISIONS				
BY	REV	DESCRIPTION	DATE	APPROVED
JAV	-	INITIAL RELEASE	06/26/18	JFU

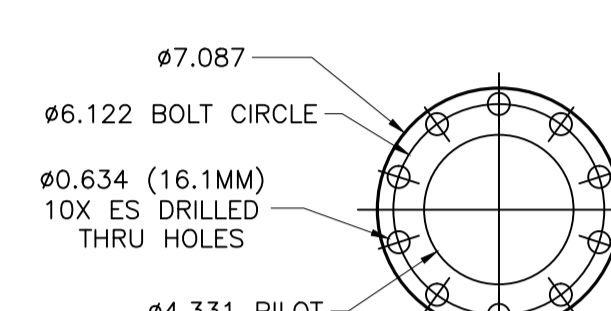
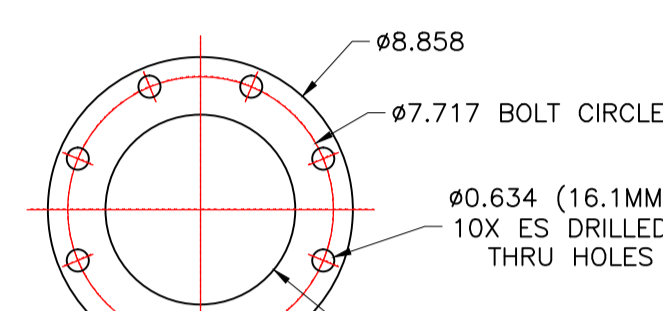
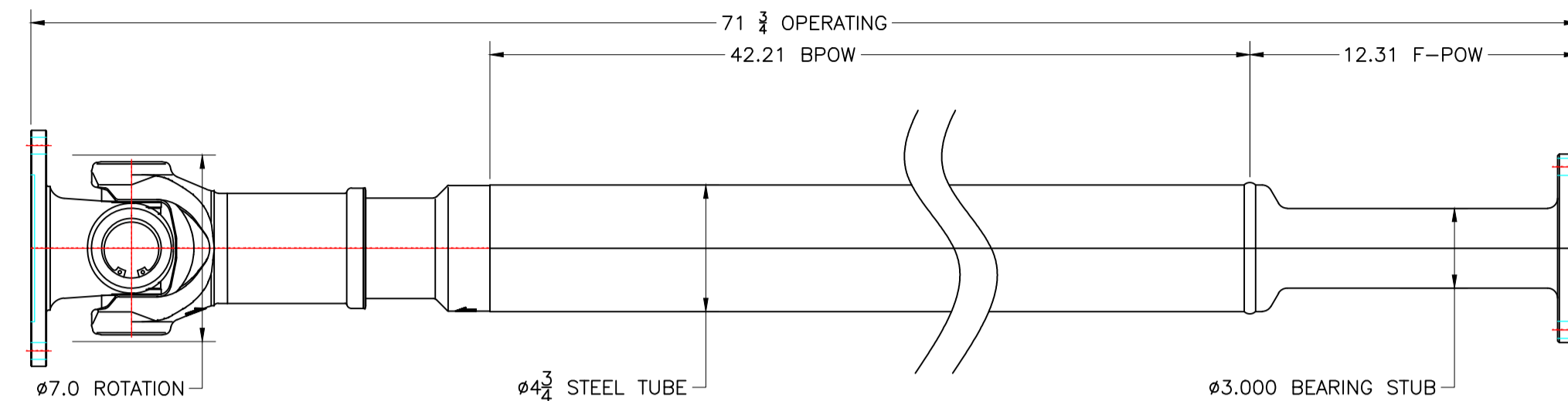

APPROVED FOR MANUFACTURE
SIGN _____
DATE _____

DRIVELINE SERVICE OF PORTLAND, INC. Telephone 503-289-2264 Toll Free 800-227-8608 www.driveshafts.com 9041 N.E. Vancouver Way Portland, Oregon 97211		THE INFORMATION CONTAINED HEREIN IS THE PROPRIETARY DATA OF DRIVELINE SERVICE OF PORTLAND AND IS NOT FOR DISSEMINATION OR DISCLOSURE IN WHOLE OR IN PART, FOR ANY PURPOSE OTHER THAN THAT FOR WHICH IT IS SUBMITTED EXCEPT AS AUTHORIZED IN WRITING BY DRIVELINE SERVICE OF PORTLAND.	
MFR. / MODEL		GWB 68755 INTERMEDIATE SHAFT	
CUSTOMER		ALL AMERICAN MARINE	
APPLICATION		RICH PASSAGE II & III	
SIZE	CAGE NO.	DWG NO.	REV
A	ON1C1	211985-02	-
SCALE	NONE	DRAWN BY	JAV 06/26/18 SHEET 1 OF 1

1. ALL DIMENSIONS IN INCHES UNLESS OTHERWISE STATED
2. DIMENSIONS ARE REFERENCE ONLY AND NOT TOLERANCED
3. SHAFT TO BE BALANCED TO ISO 1940/1 G16
4. LUBRICATE UNIVERSAL JOINTS EVERY 500 HOURS OF OPERATION
5. USE GRADE 2 NLGI LITHIUM SOAP BASED GREASE
EXAMPLE: CHEVRON ULTRA DUTY - EP

REVISIONS				
BY	REV	DESCRIPTION	DATE	APPROVED
JAV	-	INITIAL RELEASE	06/26/18	JFU

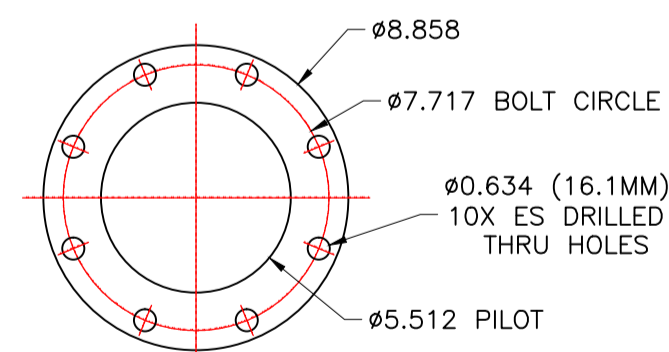
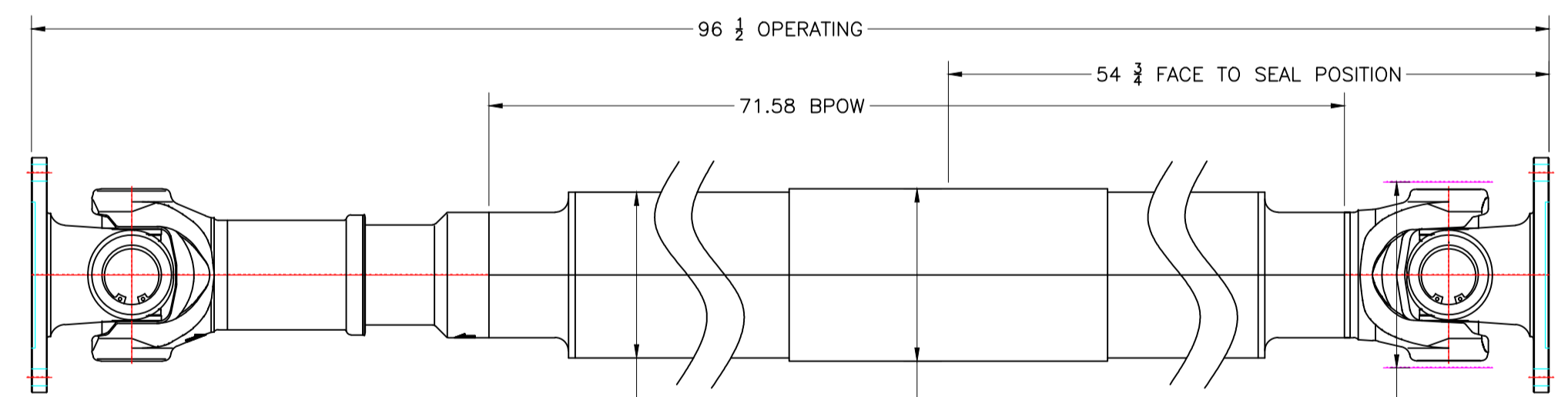

APPROVED FOR MANUFACTURE
SIGN _____
DATE _____

DRIVELINE SERVICE OF PORTLAND, INC. Telephone 503-289-2264 Toll Free 800-227-8608 www.driveshafts.com 9041 N.E. Vancouver Way Portland, Oregon 97211		THE INFORMATION CONTAINED HEREIN IS THE PROPRIETARY DATA OF DRIVELINE SERVICE OF PORTLAND AND IS NOT FOR DISSEMINATION OR DISCLOSURE IN WHOLE OR IN PART, FOR ANY PURPOSE OTHER THAN THAT FOR WHICH IT IS SUBMITTED EXCEPT AS AUTHORIZED IN WRITING BY DRIVELINE SERVICE OF PORTLAND.	
MFR. / MODEL		GWB 68755 WITH CARBON FIBER TUBE	
CUSTOMER		ALL AMERICAN MARINE	
APPLICATION		RICH PASSAGE II & III	
SIZE	CAGE NO.	DWG NO.	REV
A	ON1C1	211985-03	-
SCALE	NONE	DRAWN BY	JAV 06/26/18 SHEET 1 OF 1

teknicraft design

Teknicraft Design Ltd
 PO Box 160, Beachlands
 Auckland, New Zealand
 Tel: +64 9 536 5070
 design@teknicraft.com
 www.teknicraft.com

PROJECT: 24m Catamaran - Rich Passage 2 & 3

TITLE: Shaft details

DRAWING No:	REV:	SCALE:	PLOT SIZE:	USCG	Hull Number:
24F181-200-002	-	N.T.S	A1	TBD	TD24-53AA TD24-54AA
APPROVAL STATUS:	USCG	TEKNICRAFT:	Unless otherwise stated: • All dimensions in inches • General tolerance ± 1/16" & ± 1 degree		
Sistership	Rev.-	Checked			

CONFIDENTIAL

PROPRIETARY INFORMATION
 THIS DOCUMENT IS PROPRIETARY! NO DATA OR DESIGN SHALL BE COPIED, REPRODUCED, DISCLOSED OR SUBMITTED TO ANY THIRD PARTY, OR USED FOR CONSTRUCTION OR MANUFACTURE WHOLE OR IN PART, OF ANY PRODUCT WITHOUT PRIOR APPROVAL AND WRITTEN CONSENT FROM TEKNICRAFT DESIGN LTD, NEW ZEALAND

Rev	Date	Description	Init.	Checked
-	02 Oct 18	Issued for Construction	CL	NDW

COOPER

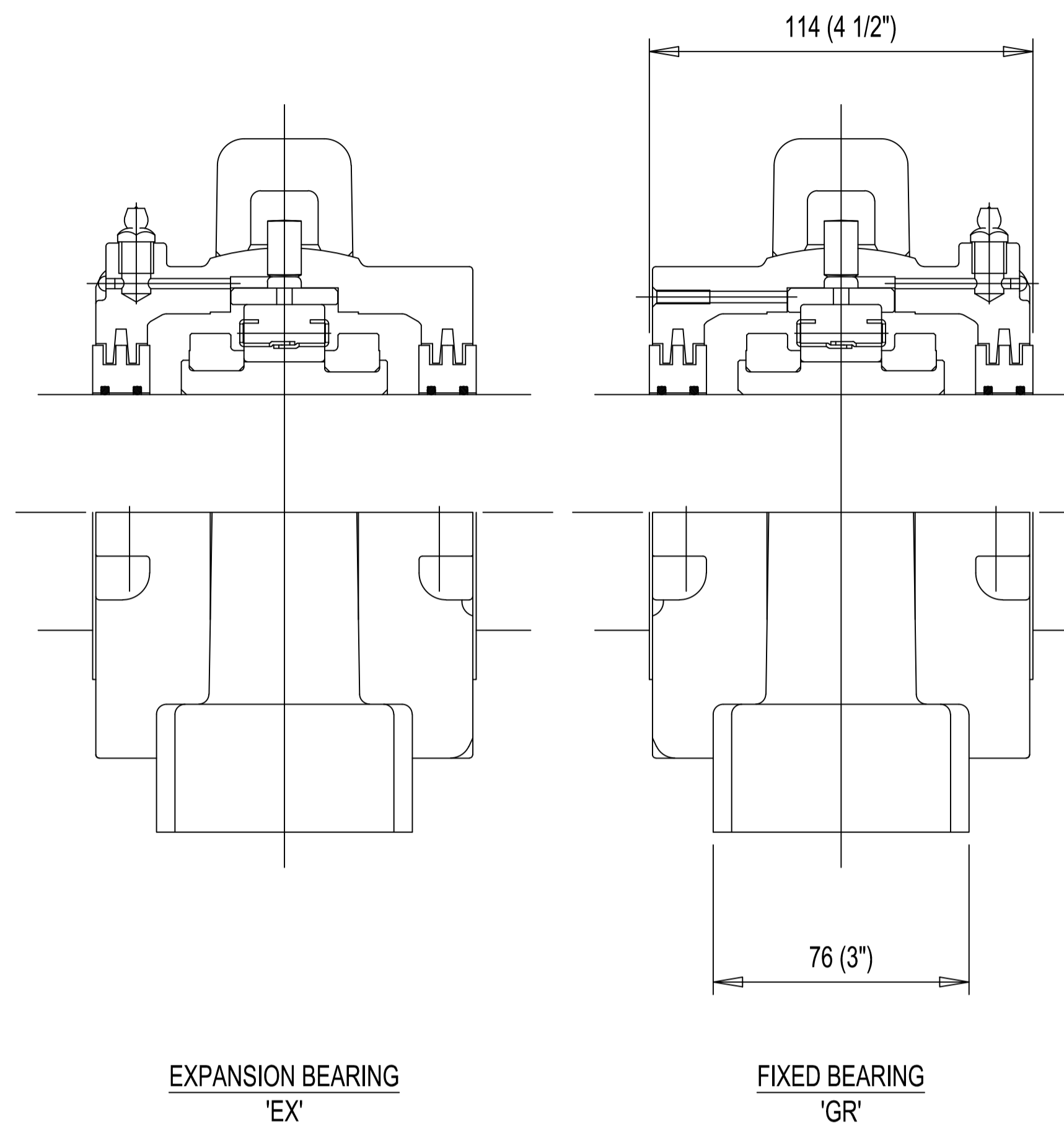
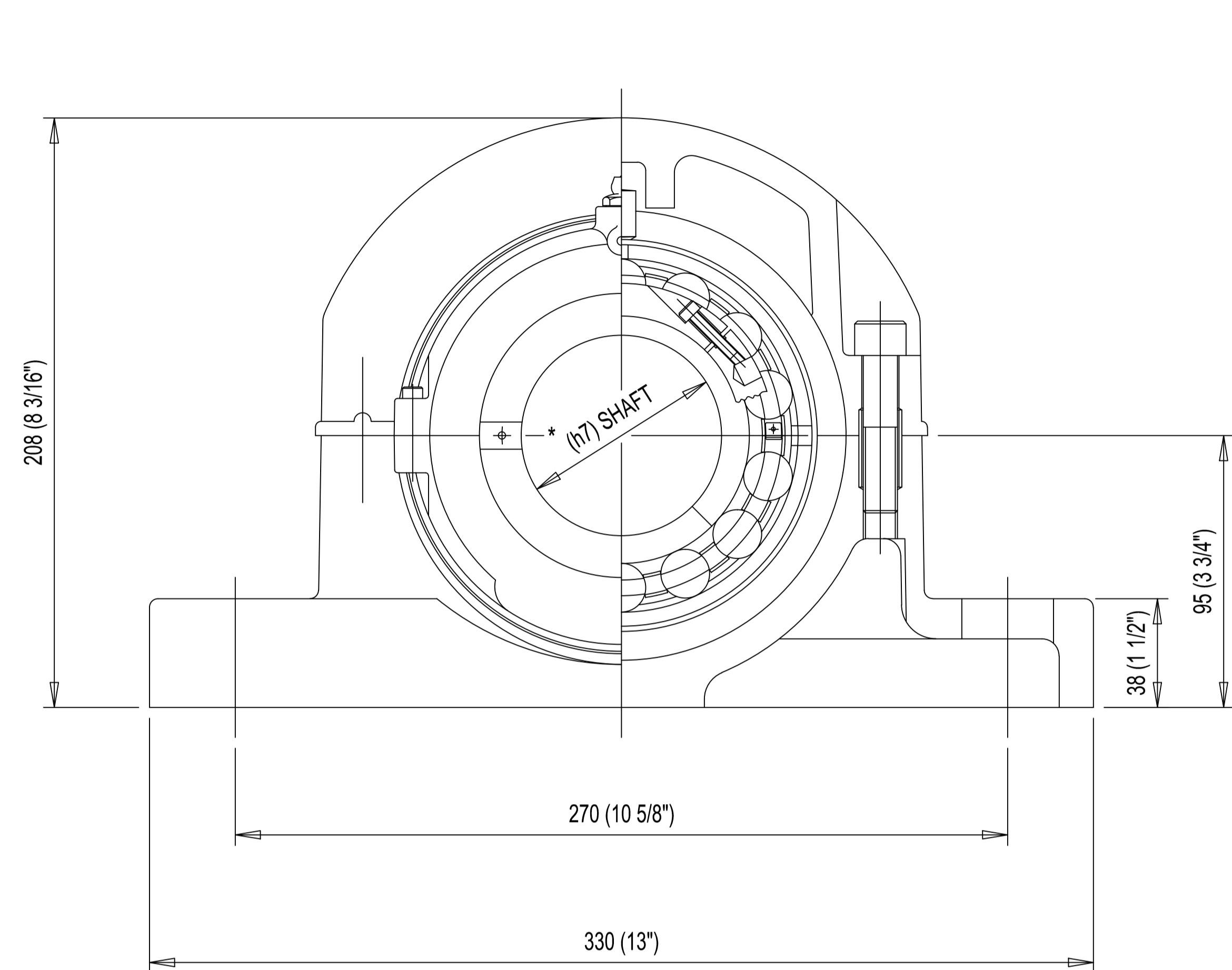

EXPANSION BEARING
'EX'

FIXED BEARING
'GR'

THIS UNIT CAN ACCOMODATE THE FOLLOWING SHAFT SIZES		
*BORE SIZE	'EX' PART NUMBER	'GR' PART NUMBER
70mm	01EBCP70MEXAT	01EBCP70MGRAT
75mm	01EBCP75MEXAT	01EBCP75MGRAT
2 11/16"	01EBCP211EXAT	01EBCP211GRAT
2 3/4"	01EBCP212EXAT	01EBCP212GRAT
2 15/16"	01EBCP215EXAT	01EBCP215GRAT
3"	01EBCP300EXAT	01EBCP300GRAT

TITLE
**LAYOUT OF
01E BCP 300 EX & GR TL**

This drawing, whether in printed or electronic form, may not be reproduced in whole or in part in any manner or form (including photocopying or storing it in any medium by electronic means and whether or not transiently or incidentally for some other use), other than with the prior written consent of Cooper Roller Bearings Co. Ltd. Every care has been taken to ensure the correctness of the information contained above but, no liability can be accepted for any errors or omissions. We reserve the right to make changes in the interest of technical progress.

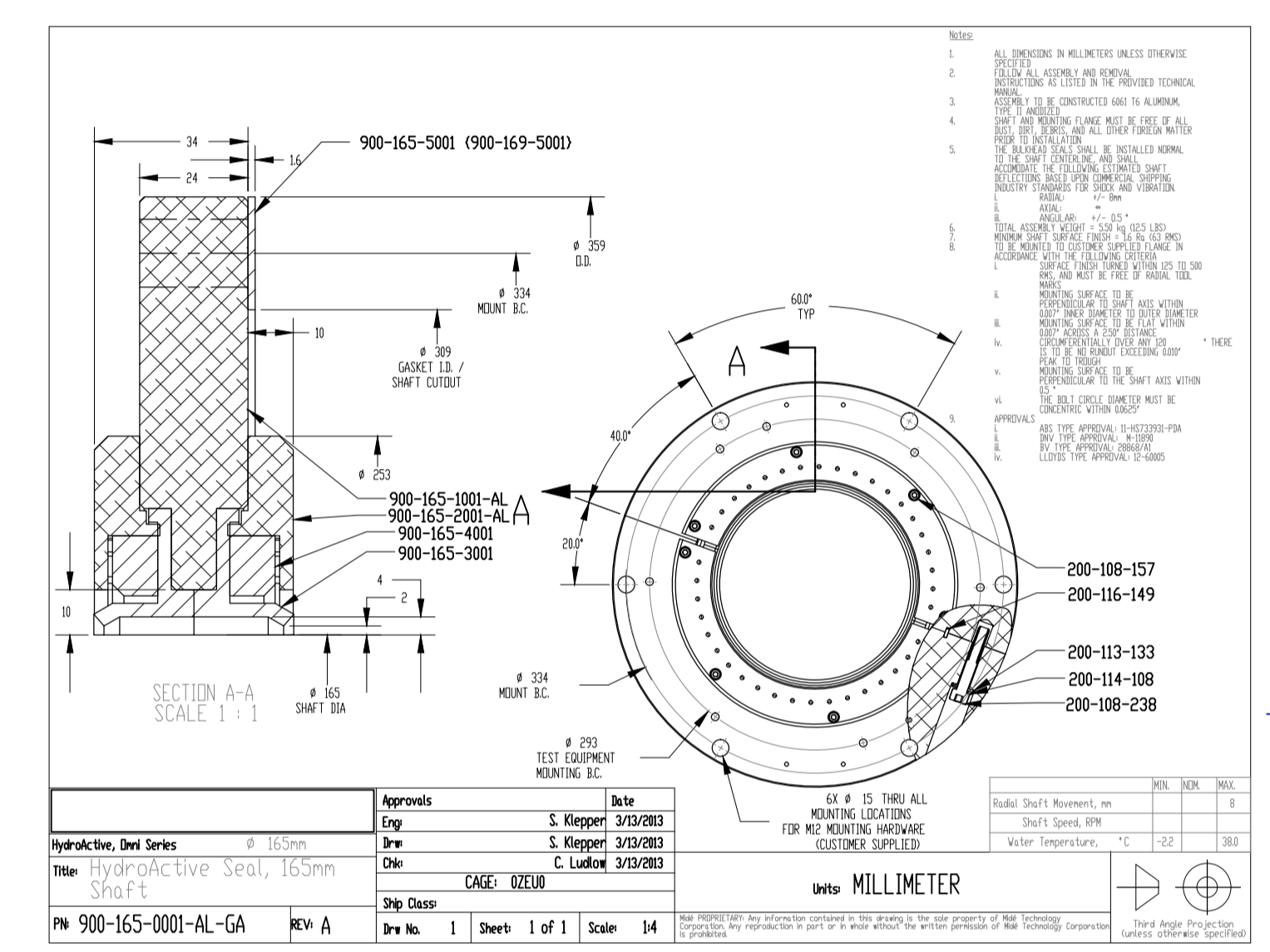
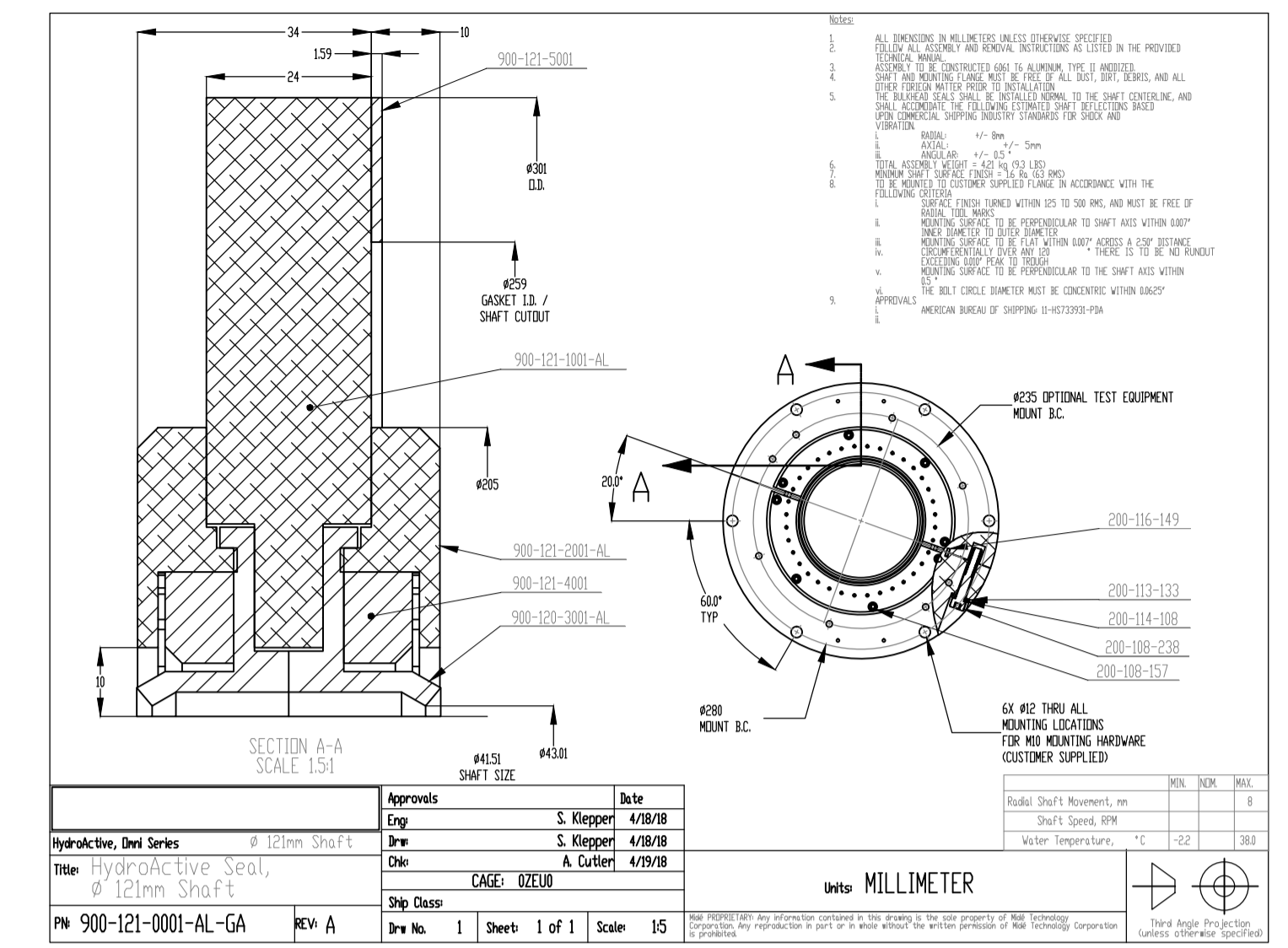

Rev	Date	Description	Init.	Checked
-	02 Oct 18	Issued for Construction	CL	NDW

Teknicraft Design Ltd
PO Box 160, Beachlands
Auckland, New Zealand
Tel: +64 9 536 5070
design@teknicraft.com
www.teknicraft.com

PROJECT: 24m Catamaran - Rich Passage 2 & 3
TITLE: Bearing & Shaft seals

DRAWING No: T24F181-200-003	REV: -	SCALE: N.T.S	PLOT SIZE: A1	USCG TBD	Hull Number: TD24-53AA TD24-54AA
---------------------------------------	-----------	-----------------	------------------	-------------	--

APPROVAL STATUS: USCG Sistership	Rev. -	TEKNICRAFT: Checked	Rev. -	Unless otherwise stated: • All dimensions in inches • General tolerance ± .118" & ± 1 degree
--	--------	------------------------	--------	--

CONFIDENTIAL

© PROPRIETARY INFORMATION
THIS DOCUMENT IS PROPRIETARY! NO DATA OR DESIGN SHALL BE COPIED, REPRODUCED, DISCLOSED OR SUBMITTED TO ANY THIRD PARTY, OR USED FOR CONSTRUCTION OR MANUFACTURE WHOLE OR IN PART, OF ANY PRODUCT WITHOUT PRIOR APPROVAL AND WRITTEN CONSENT FROM TEKNICRAFT DESIGN LTD, NEW ZEALAND

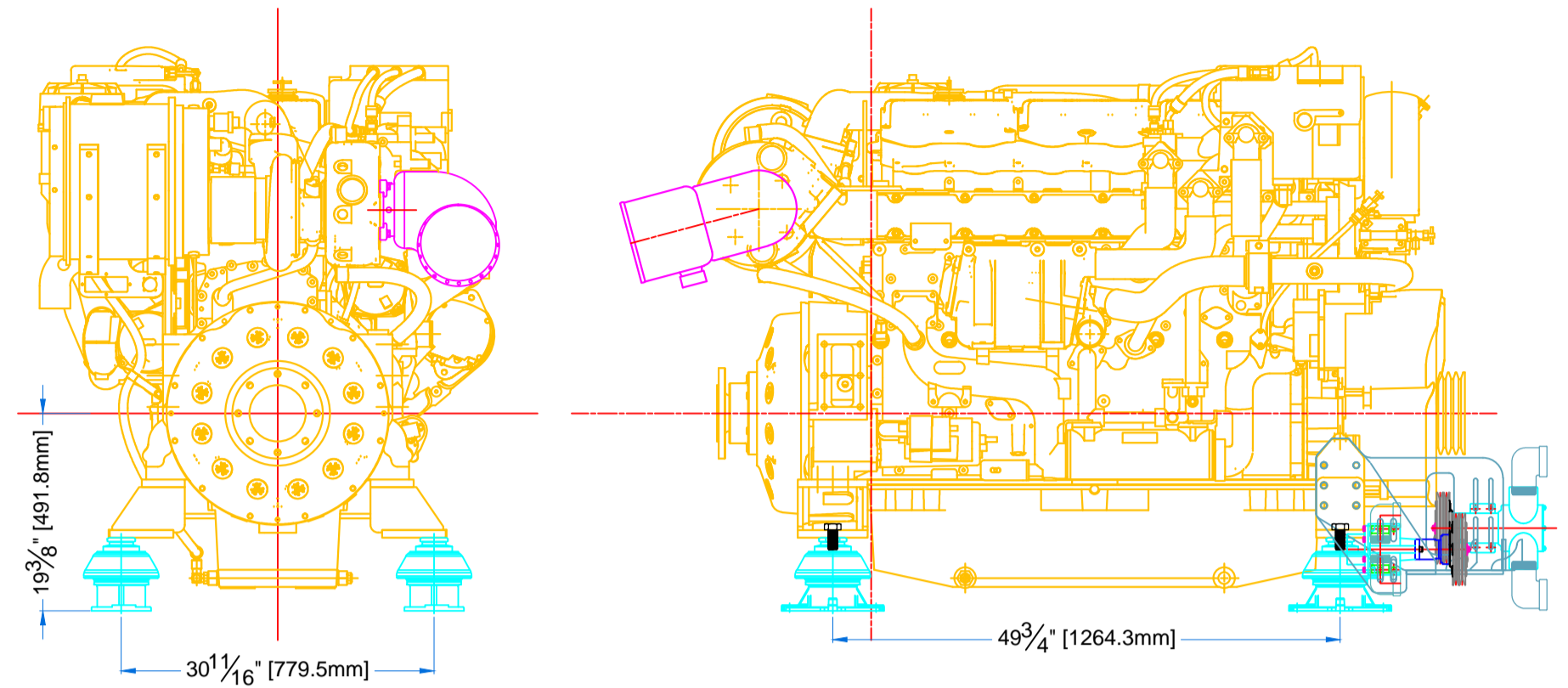
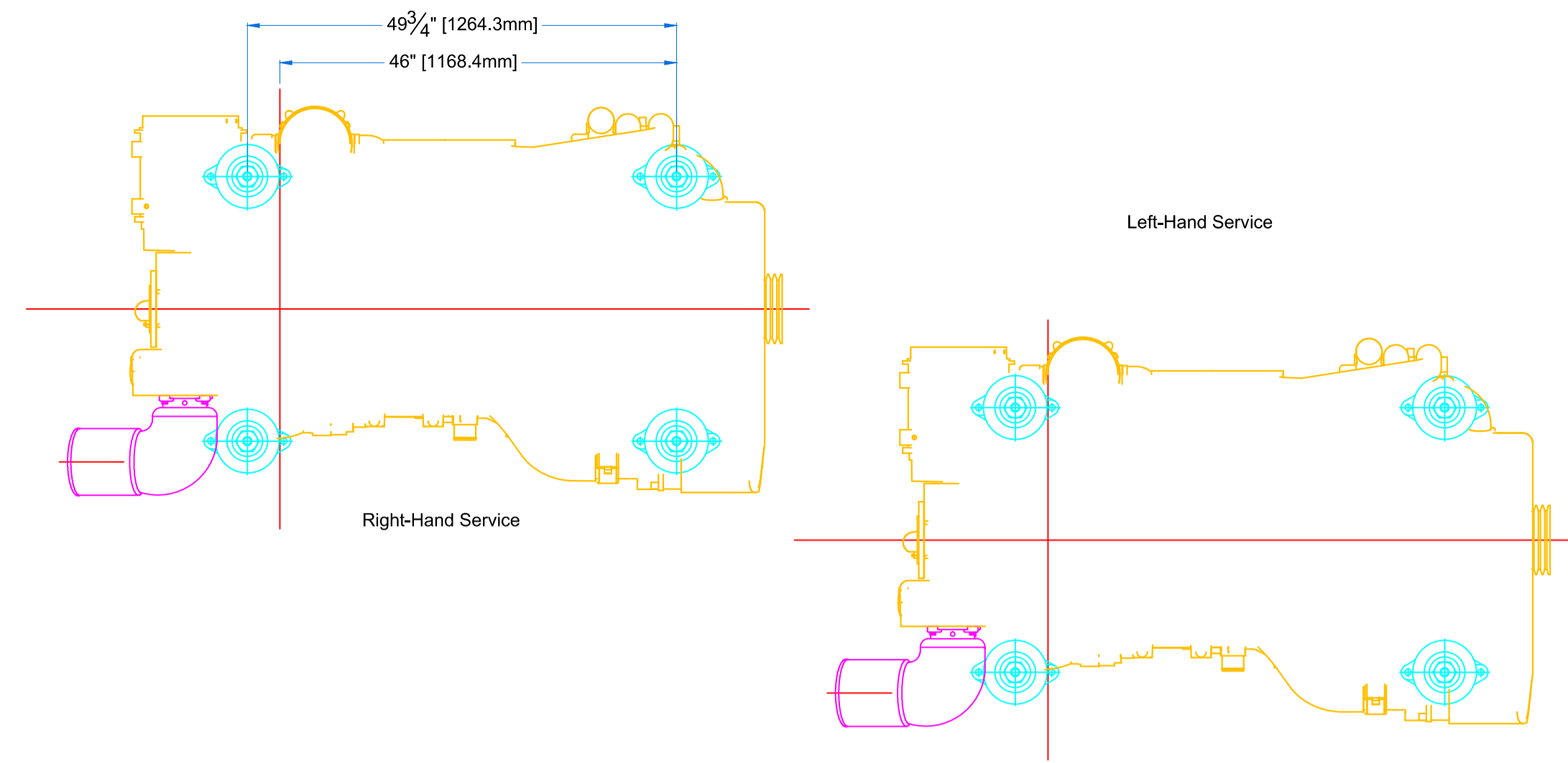

Engine Layout Schematic
Scale 3/4"=1'-0"

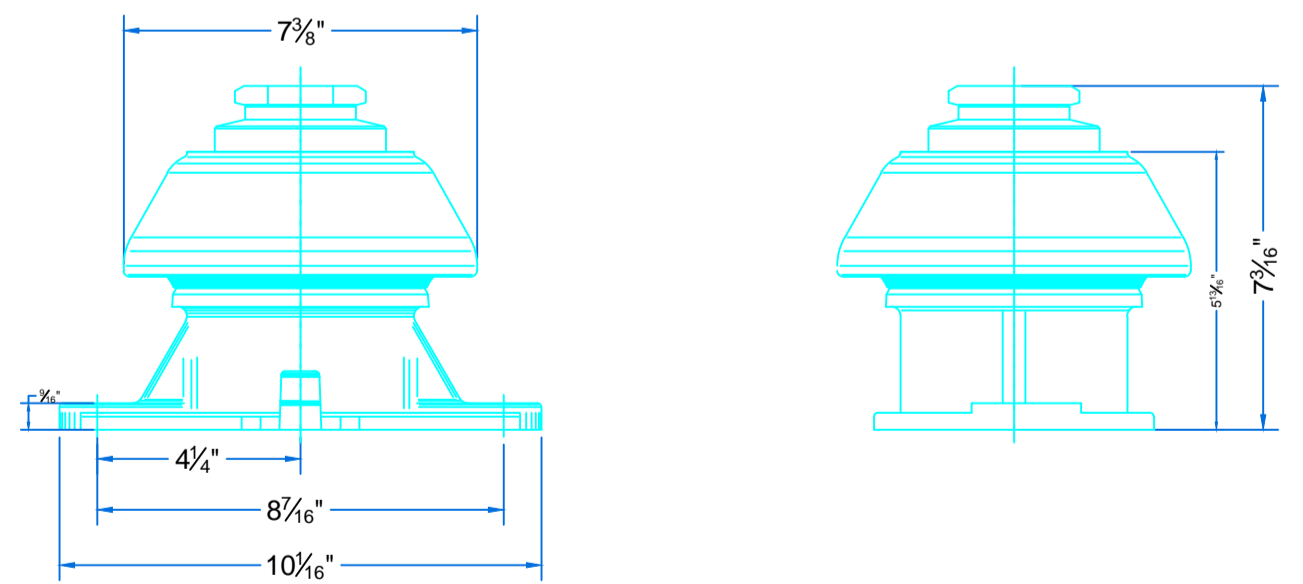
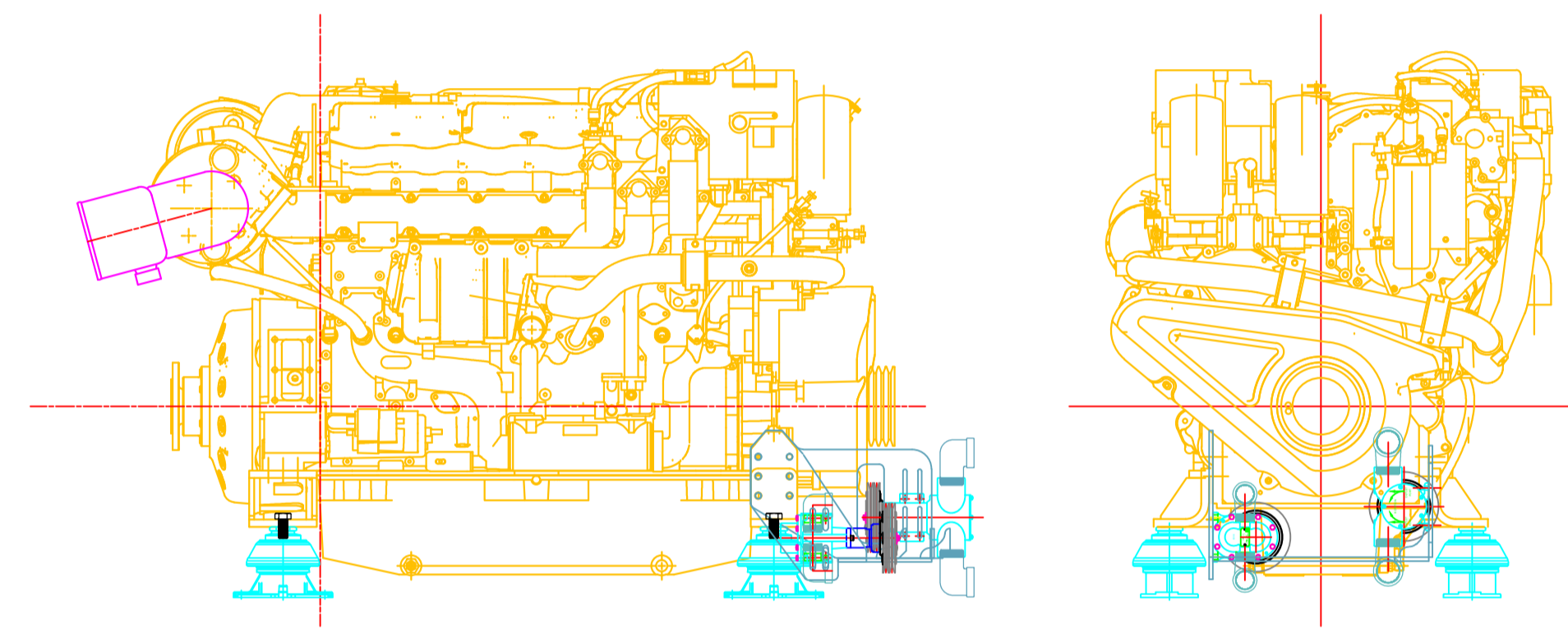
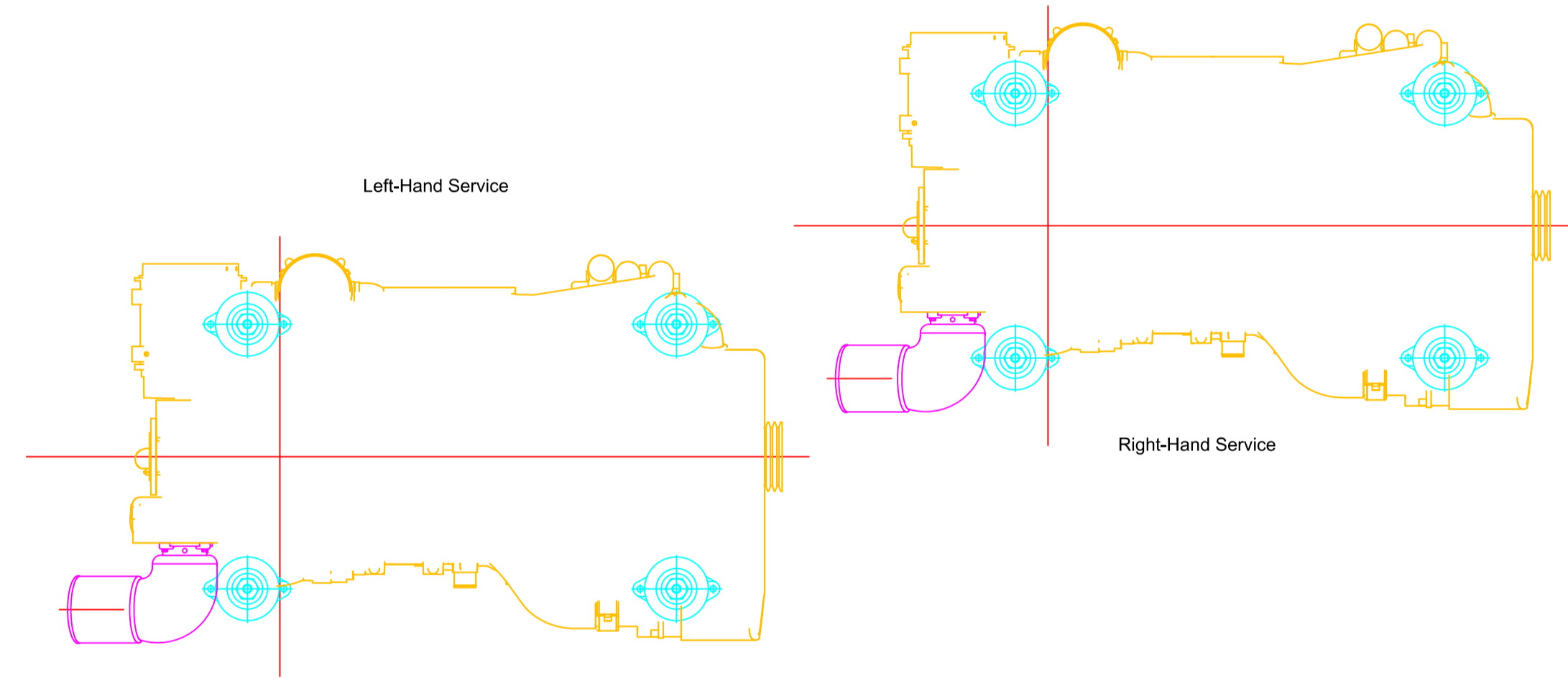

Engine Mount Detail
Scale 3"=1'-0"



Teknicraft Design Ltd
PO Box 160, Beachlands
Auckland, New Zealand
Tel: +64 9 536 5070
design@teknicraft.com
www.teknicraft.com

PROJECT: 24m Catamaran - Rich Passage 2 & 3
TITLE: Main Engine footprint

DRAWING No: T24F181-200-004	REV: -	SCALE: 1"=1'	PLOT SIZE: A1	USCG TBD	Hull Number: TD24-53AA TD24-54AA
APPROVAL STATUS: USCG <i>Sistership</i>	Rev. -	TEKNICRAFT: <i>Checked</i>	Rev. -	<small>Unless otherwise stated: • All dimensions in inches • General tolerance ± .116" & ± 1 degree</small>	

CONFIDENTIAL

PROPRIETARY INFORMATION
 THIS DOCUMENT IS PROPRIETARY! NO DATA OR DESIGN SHALL BE COPIED, REPRODUCED, DISCLOSED OR SUBMITTED TO ANY THIRD PARTY, OR USED FOR CONSTRUCTION OR MANUFACTURE WHOLE OR IN PART, OF ANY PRODUCT WITHOUT PRIOR APPROVAL AND WRITTEN CONSENT FROM TEKNICRAFT DESIGN LTD, NEW ZEALAND

-	02 Oct 18	Issued for Construction	CL	NDW
Rev	Date	Description	Init.	Checked

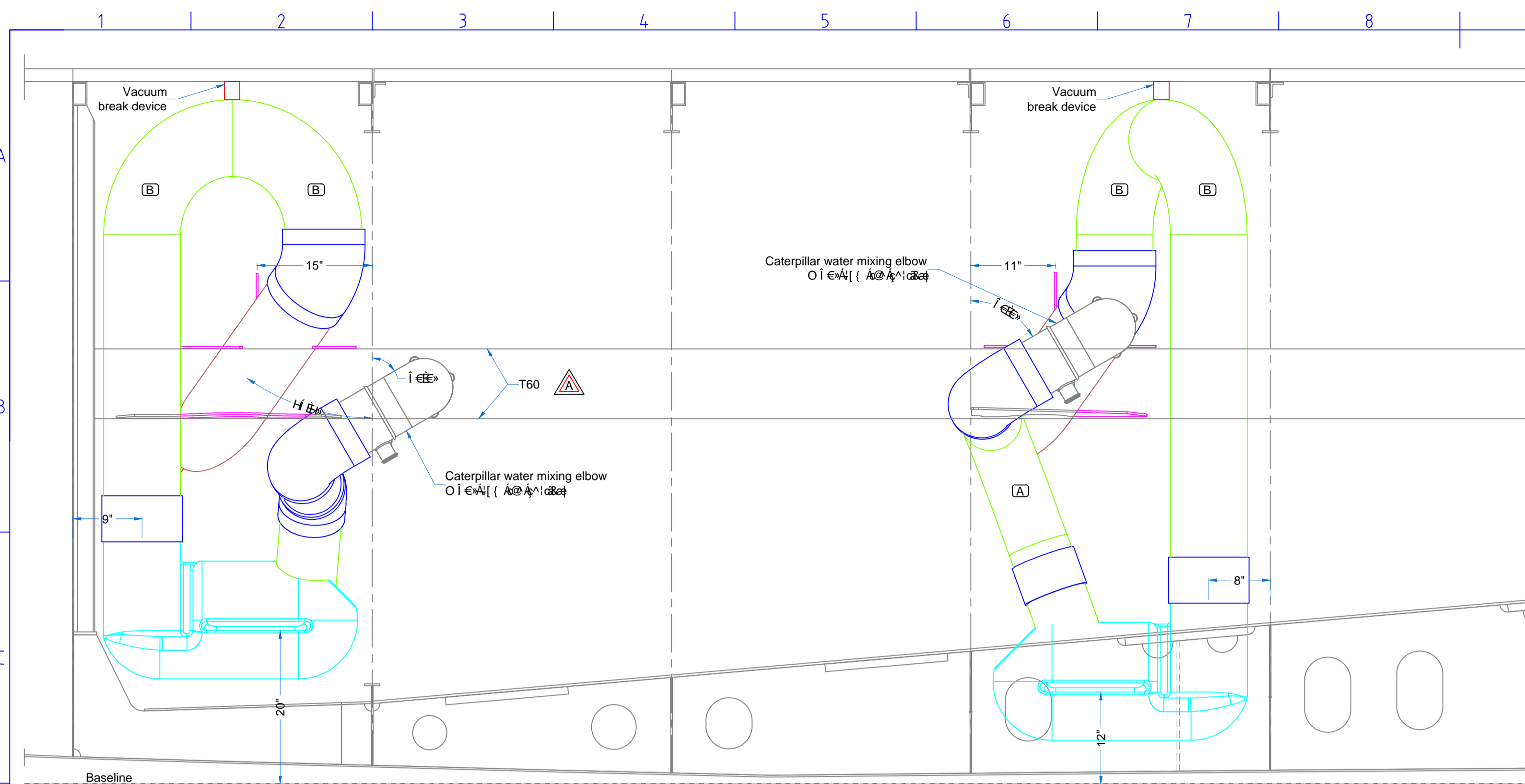

Portside Profile View
Scale 1"=1'

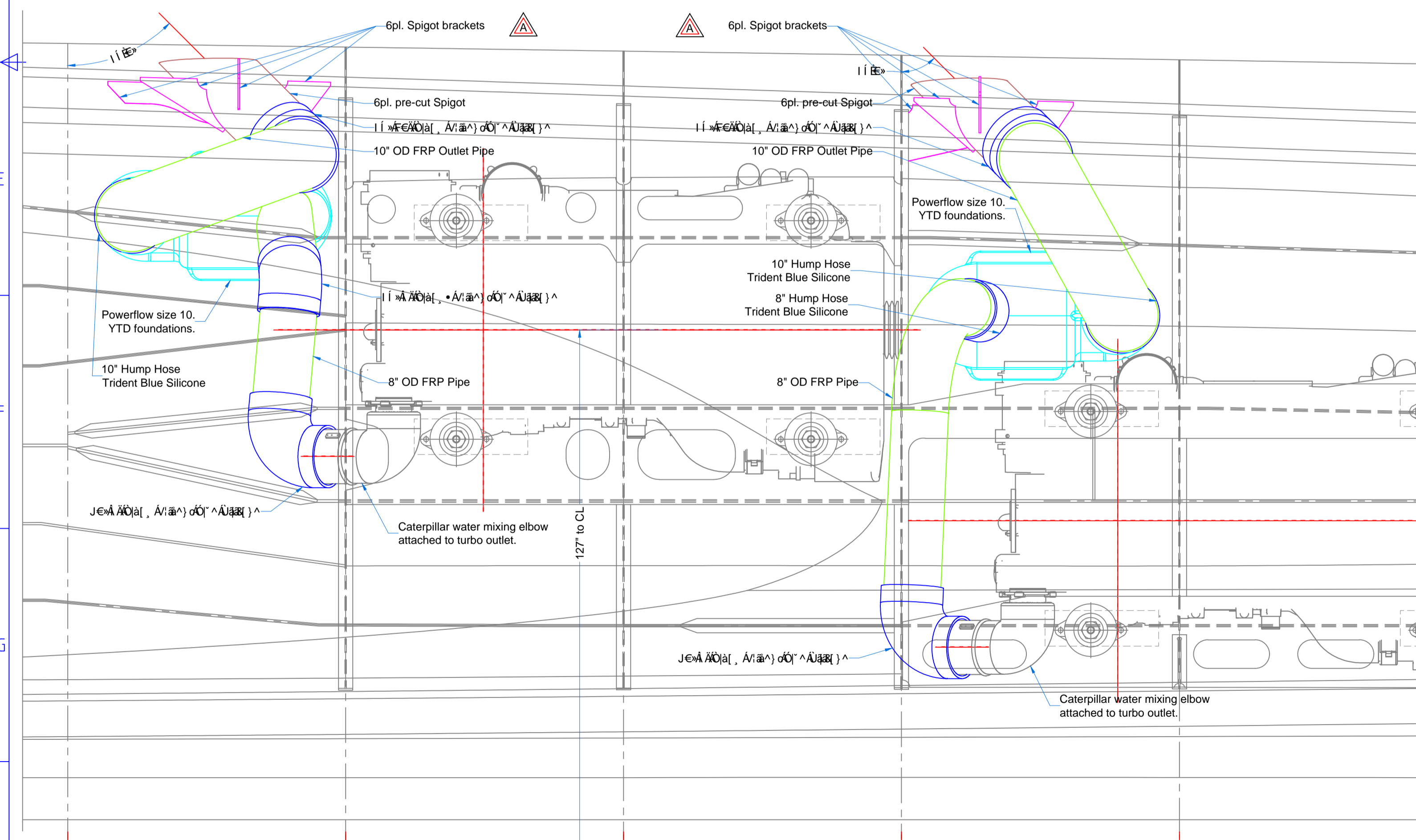

Portside Plan View
Scale 1"=1'

Rev	Date	Description	Init.	Checked
A	22 Nov 18	Lower brackets added	CL	NDW
-	04 Sep 18	Issued for Construction	CL	NDW

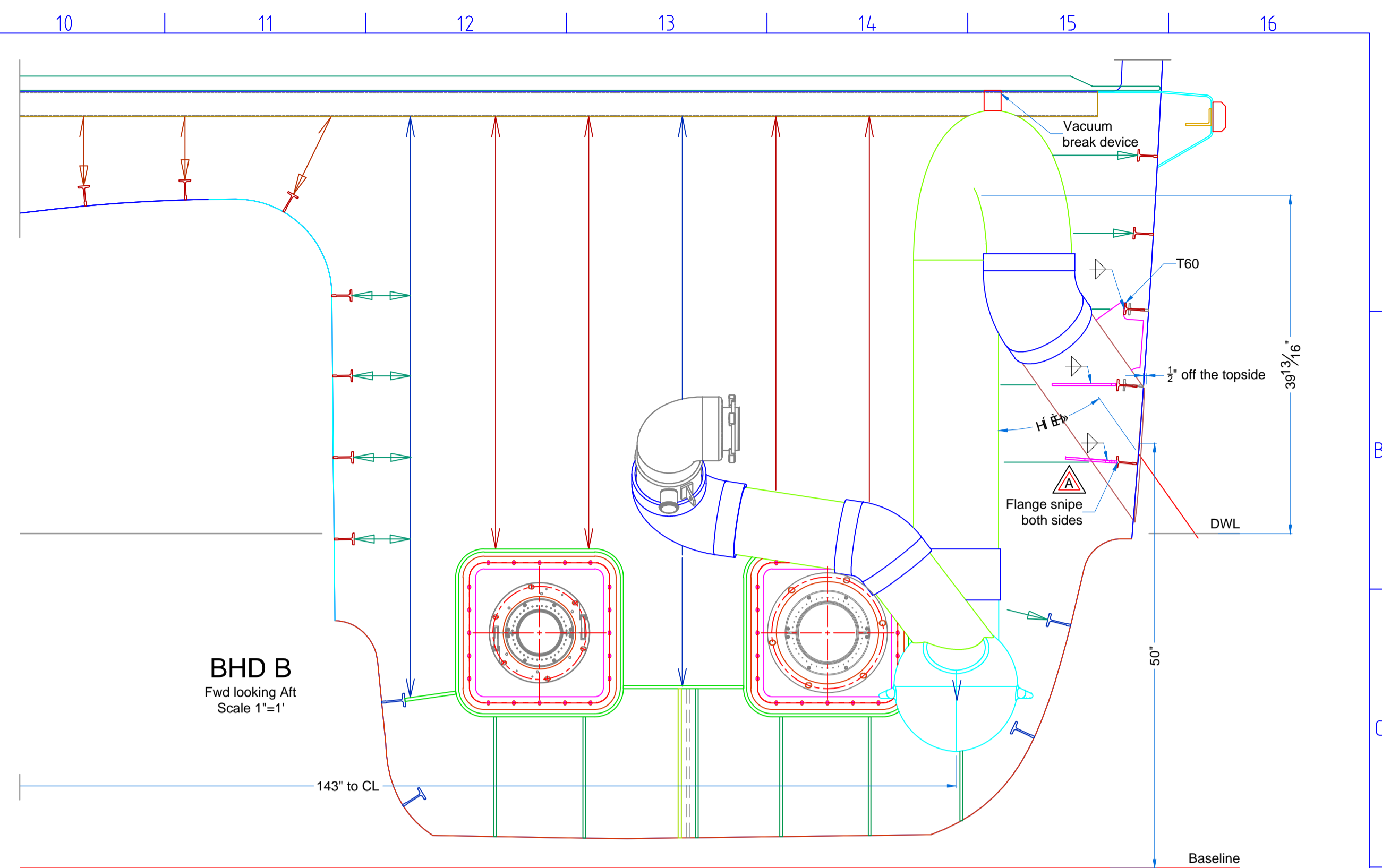

BHD B
Fwd looking Aft
Scale 1"=1'

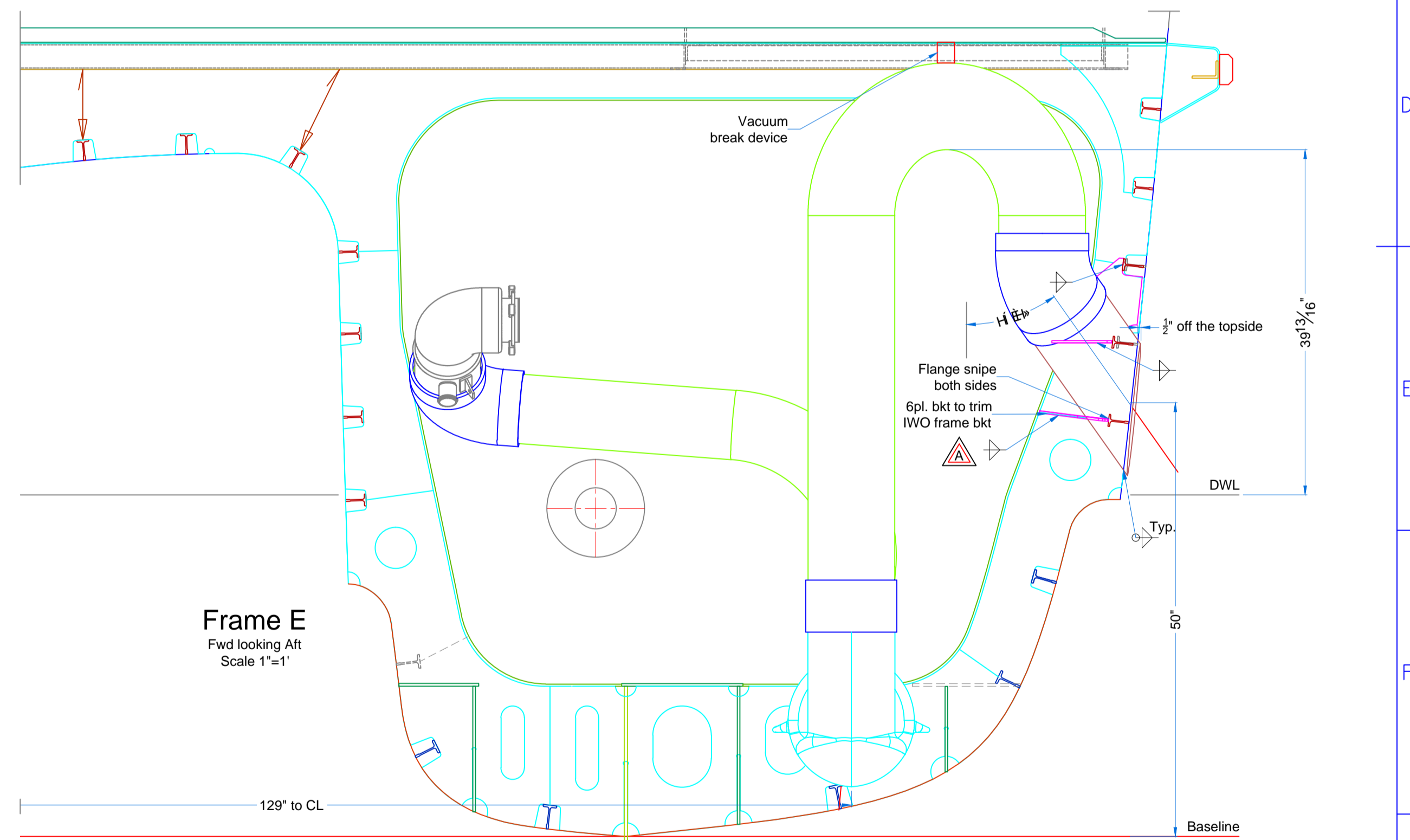

Frame E
Fwd looking Aft
Scale 1"=1'

Label	Reference	Qty.
A	8" R410mm pipe	1
B	10" R400mm pipe	4

- NOTES
- Refer to drawing: T24F181-101-001 for typical hull construction details and welding notes.
 - All sleeves, bellows and elbows to have dual stainless steel clamps.
 - Exact dimensions to be verified on site to best suit installation.
 - Glassfibre Engine & Genset Muffler and tube to be fabricated using high temperature resistant resin to meet USCG requirements.
 - Exhaust to be supported to deck head with suitable, flexible hanging brackets.
 - Silencer to be fitted with a drain cock at the lowest point.
 - System manufacturer to verify that system will be within engine manufacturer's backpressure specification and flow velocities requirements.
 - Trident connectors to be "Blue" silicon type.
 - Vacuum break device to be fitted.
 - All welding to be double continuous in way of the hull penetration.

Teknicraft Design Ltd
PO Box 160, Beachlands
Auckland, New Zealand
Tel: +64 9 536 5070
design@teknicraft.com
www.teknicraft.com

PROJECT: 24m Catamaran - Rich Passage 2 & 3

TITLE: ME Port Side Exhaust Arrangement

DRAWING No: T24F181-250-001	REV: A	SCALE: 1"=1'	PLOT SIZE: A1	USCG: TBD	Hull Number: TD24-53AA TD24-54AA
APPROVAL STATUS: USCG Sistership	Rev.:	TEKNICRAFT: Checked	Rev. A	Unless otherwise stated: • All dimensions in inches • General tolerance ± 1/16" & ± 1 degree	

CONFIDENTIAL

PROPRIETARY INFORMATION
 THIS DOCUMENT IS PROPRIETARY! NO DATA OR DESIGN SHALL BE COPIED, REPRODUCED, DISCLOSED OR SUBMITTED TO ANY THIRD PARTY, OR USED FOR CONSTRUCTION OR MANUFACTURE WHOLE OR IN PART, OF ANY PRODUCT WITHOUT PRIOR APPROVAL AND WRITTEN CONSENT FROM TEKNICRAFT DESIGN LTD, NEW ZEALAND

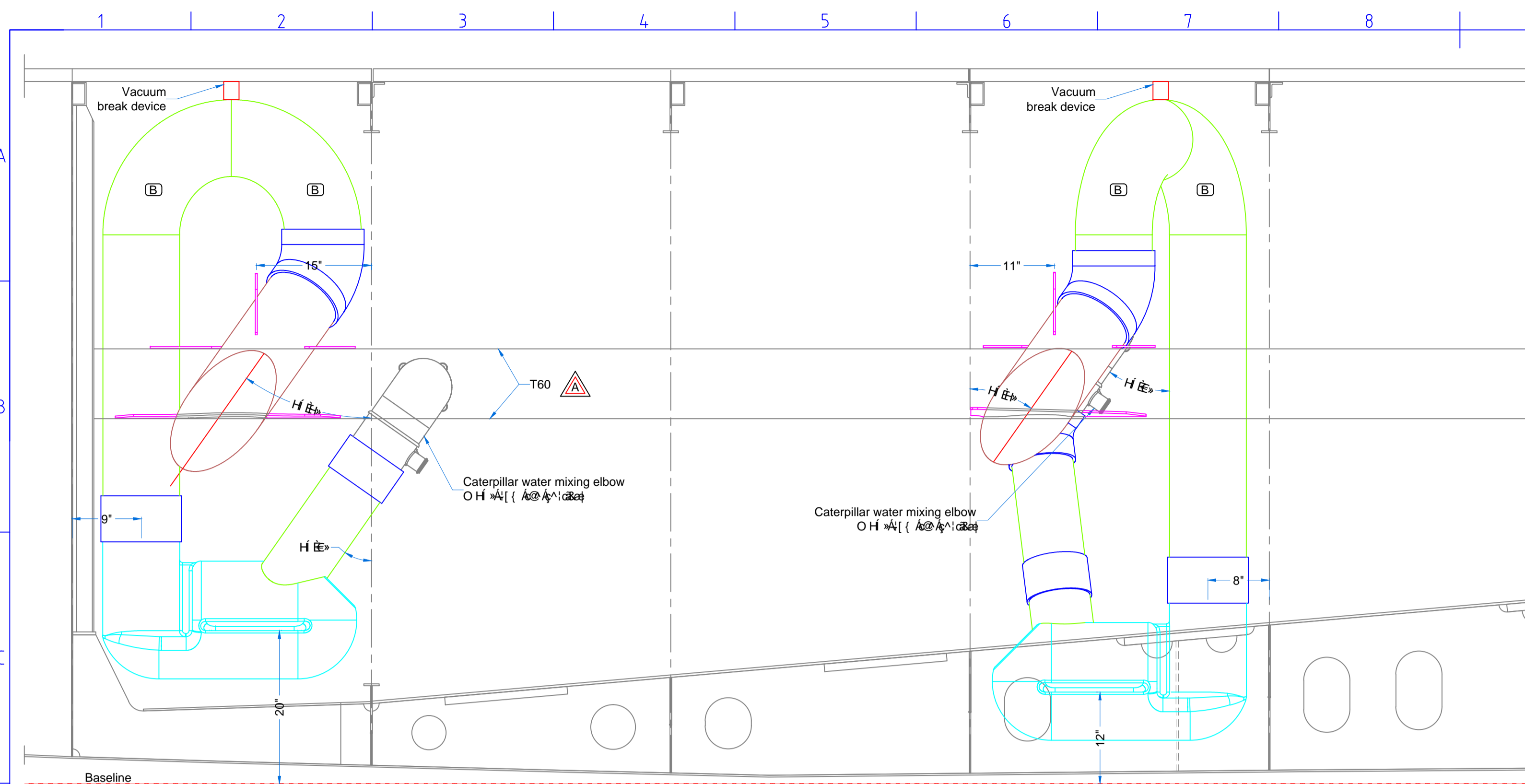

Starboard Profile View
Scale 1"=1'

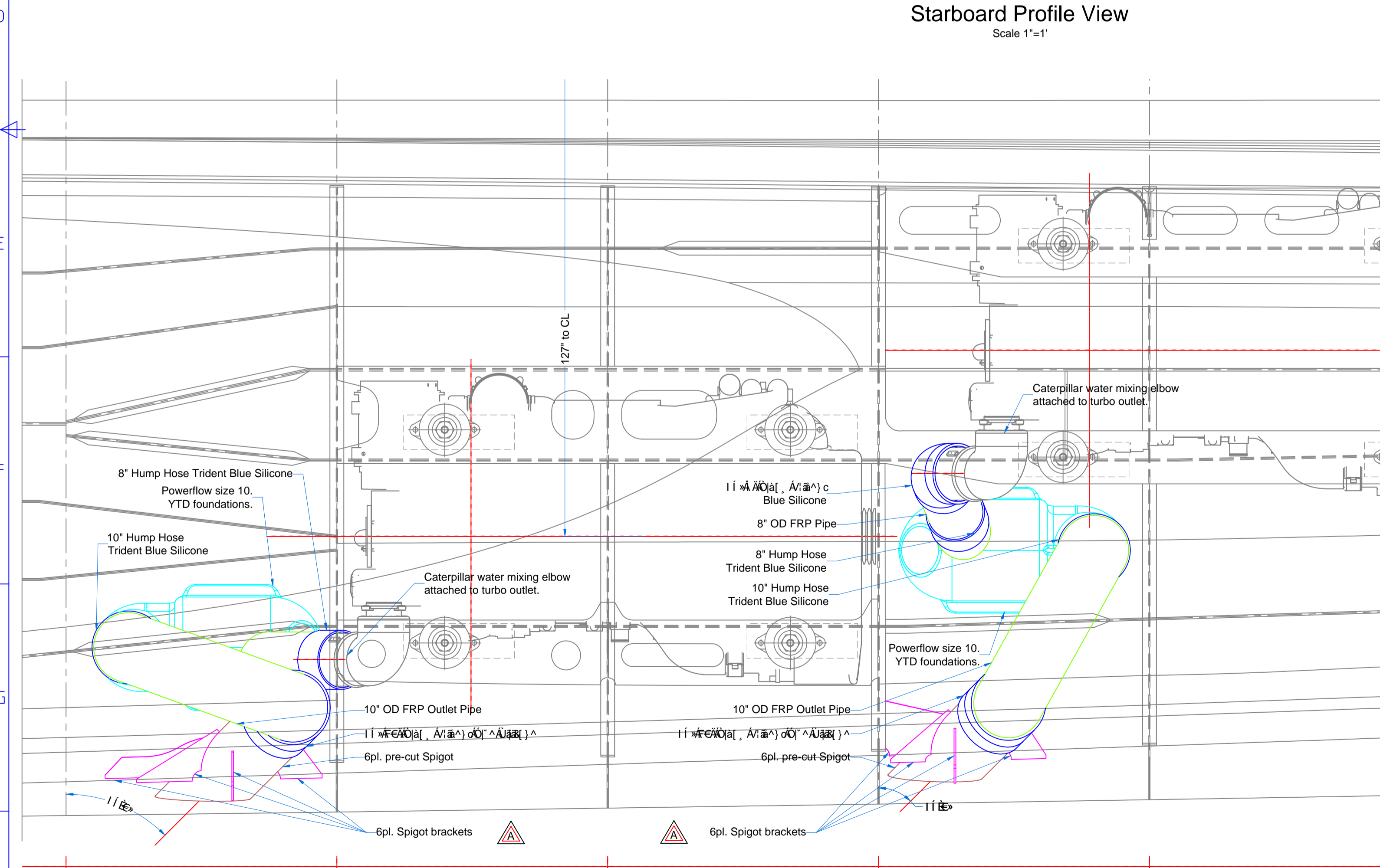

STBD Plan View
Scale 1"=1'

Rev	Date	Description	Init.	Checked
A	22 Nov 18	Lower brackets added	CL	NDW
-	04 Sep 18	Issued for Construction	CL	NDW

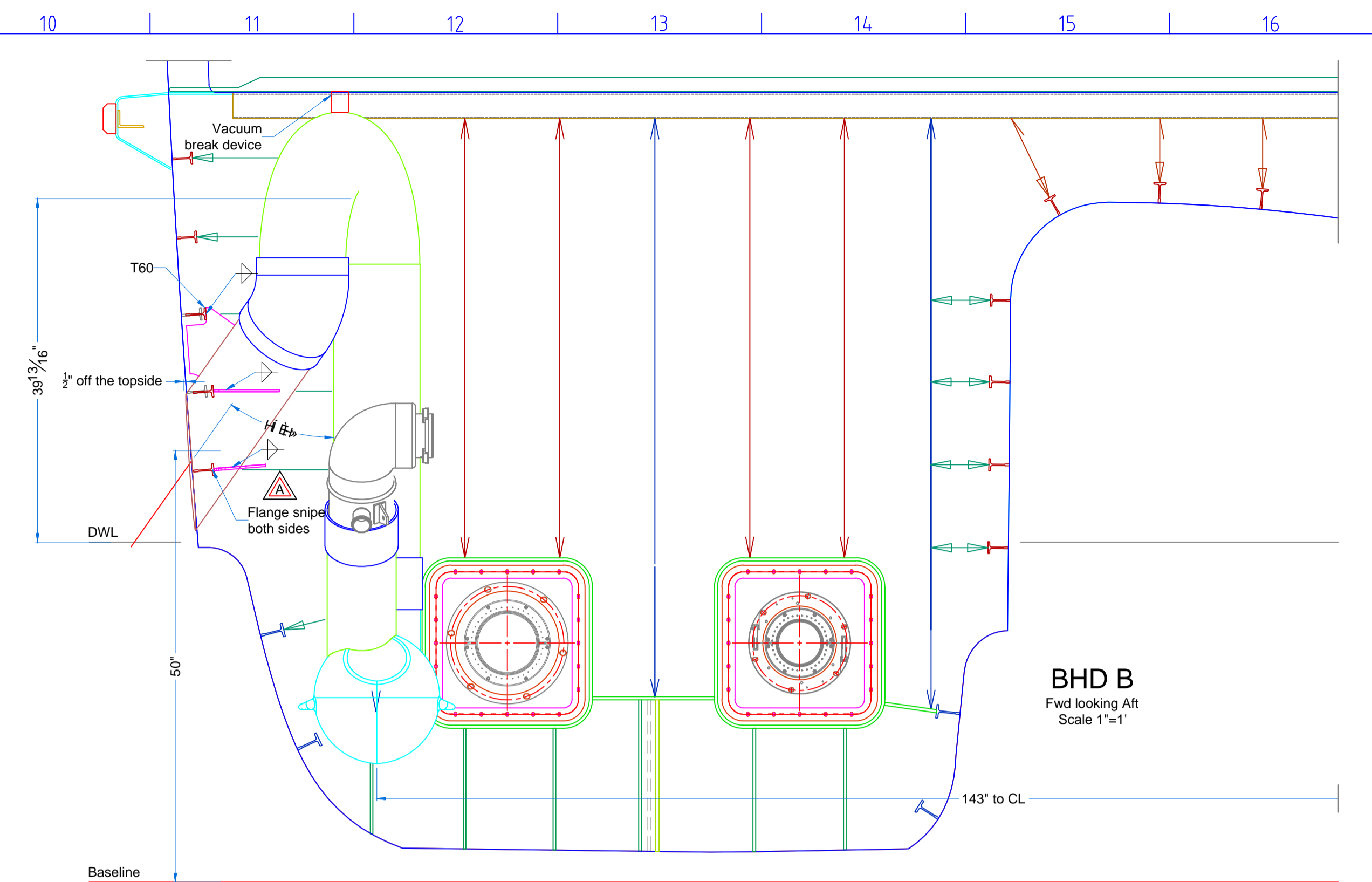

BHD B
Fwd looking Aft
Scale 1"=1'

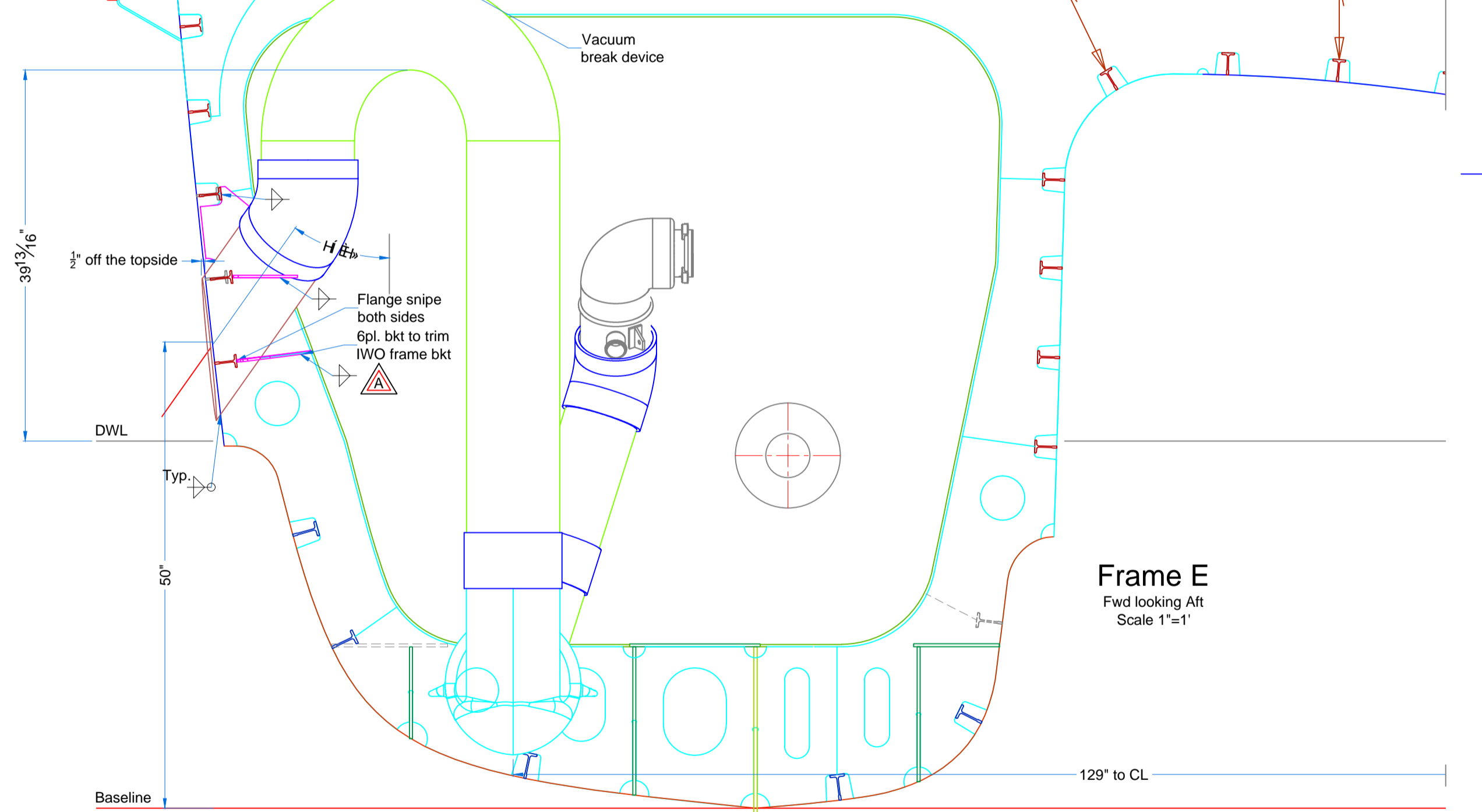

Frame E
Fwd looking Aft
Scale 1"=1'

Label	Reference	Qty.
B	10" R400mm pipe	4

- NOTES**
- Refer to drawing: T24F181-101-001 for typical hull construction details and welding notes.
 - All sleeves, bellows and elbows to have dual stainless steel clamps.
 - Exact dimensions to be verified on site to best suit installation.
 - Glassfibre Engine & Genset Muffler and tube to be fabricated using high temperature resistant resin to meet USCG requirements.
 - Exhaust to be supported to deck head with suitable, flexible hanging brackets.
 - Silencer to be fitted with a drain cock at the lowest point.
 - System manufacturer to verify that system will be within engine manufacturer's backpressure specification and flow velocities requirements.
 - Trident connectors to be "Blue" silicon type.
 - Vacuum break device to be fitted.
 - All welding to be double continuous in way of the hull penetration.

Teknicraft Design Ltd
PO Box 160, Beachlands
Auckland, New Zealand
Tel: +64 9 536 5070
design@teknicraft.com
www.teknicraft.com

PROJECT: 24m Catamaran - Rich Passage 2 & 3

TITLE: ME Starboard Exhaust Arrangement

DRAWING No: T24F181-250-002	REV: A	SCALE: 1"=1'	PLOT SIZE: A1	USCG TBD	Hull Number: TD24-53AA TD24-54AA
APPROVAL STATUS: USCG Sistership	Rev.-	TEKNICRAFT: Checked	Rev. A	Unless otherwise stated: • All dimensions in inches • General tolerance ± 1/16" & ± 1 degree	

CONFIDENTIAL

PROPRIETARY INFORMATION
 THIS DOCUMENT IS PROPRIETARY! NO DATA OR DESIGN SHALL BE COPIED, REPRODUCED, DISCLOSED OR SUBMITTED TO ANY THIRD PARTY, OR USED FOR CONSTRUCTION OR MANUFACTURE WHOLE OR IN PART, OF ANY PRODUCT WITHOUT PRIOR APPROVAL AND WRITTEN CONSENT FROM TEKNICRAFT DESIGN LTD, NEW ZEALAND

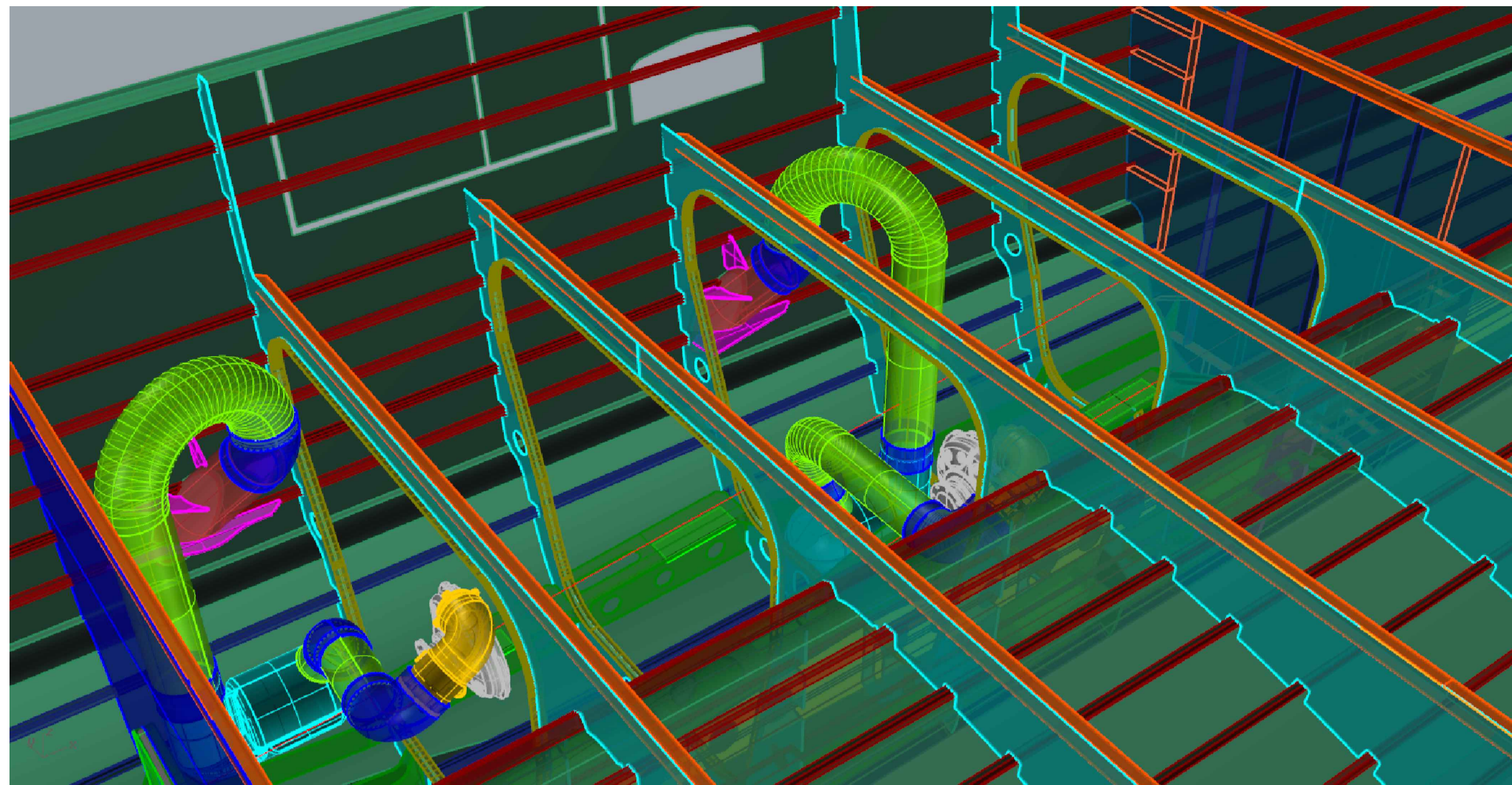

Perspective View - Port Side
Looking Fwd

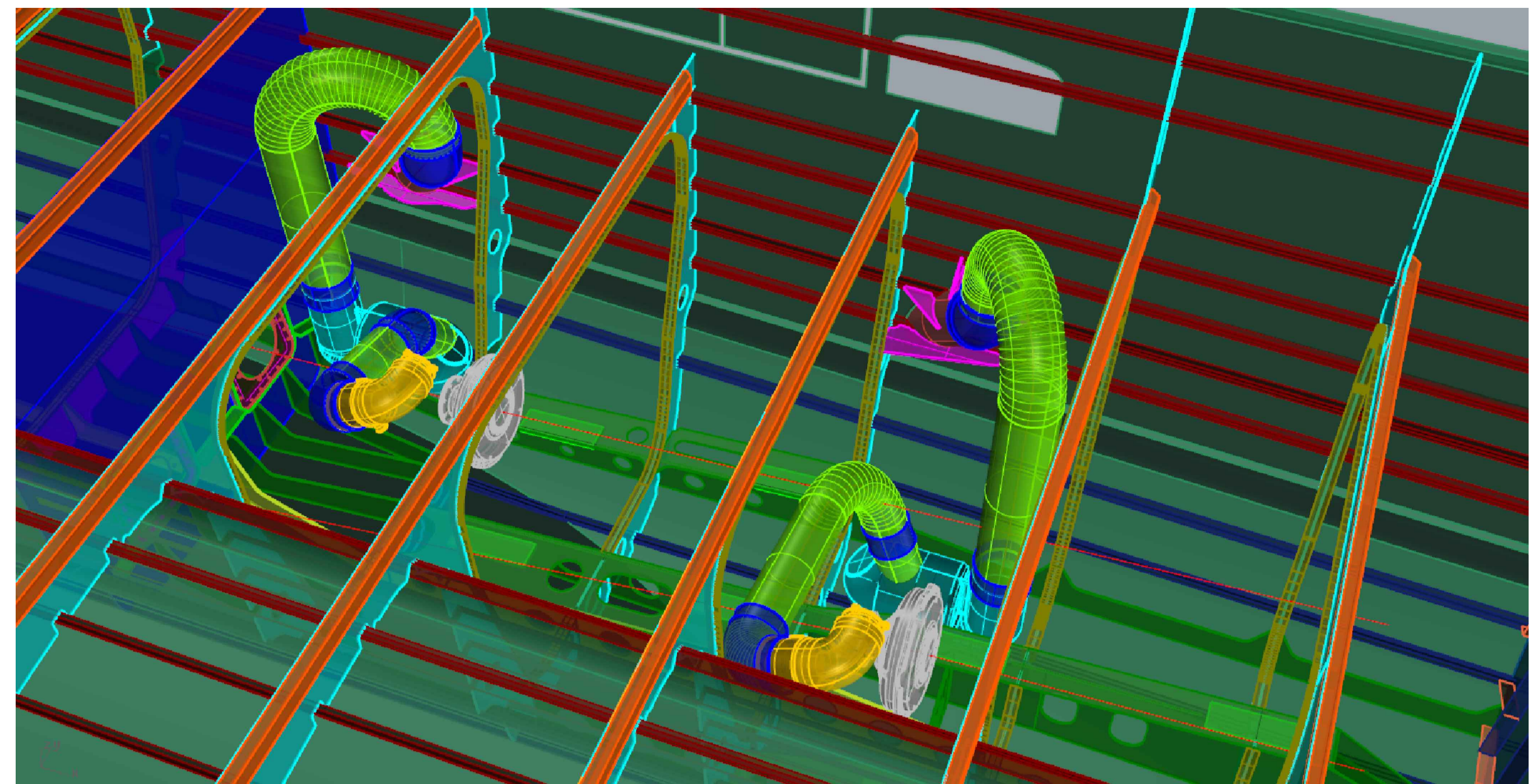

Perspective View - Port Side
Looking Bwd

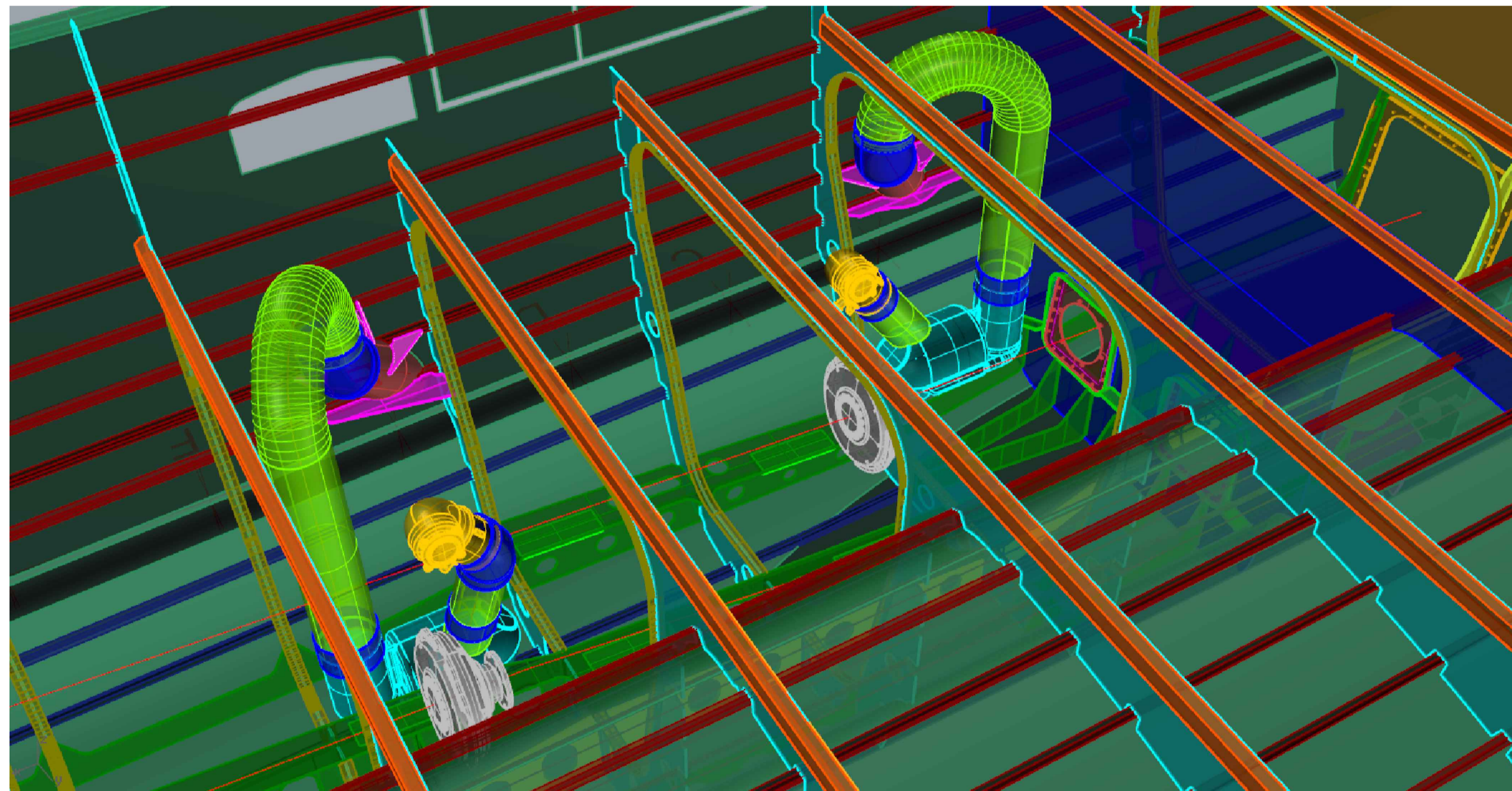

Perspective View - Starboard
Looking Fwd

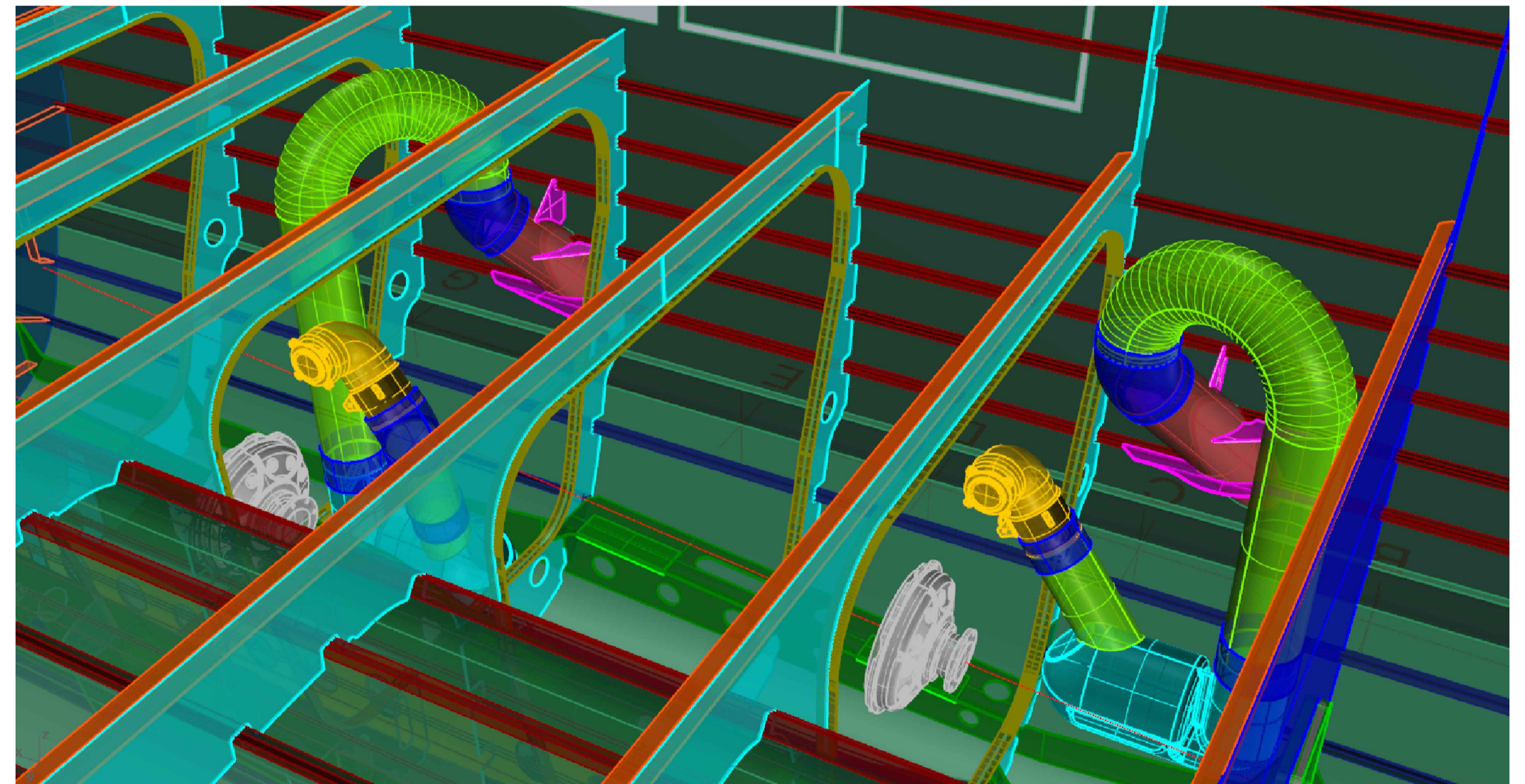

Perspective View - Starboard
Looking Bwd

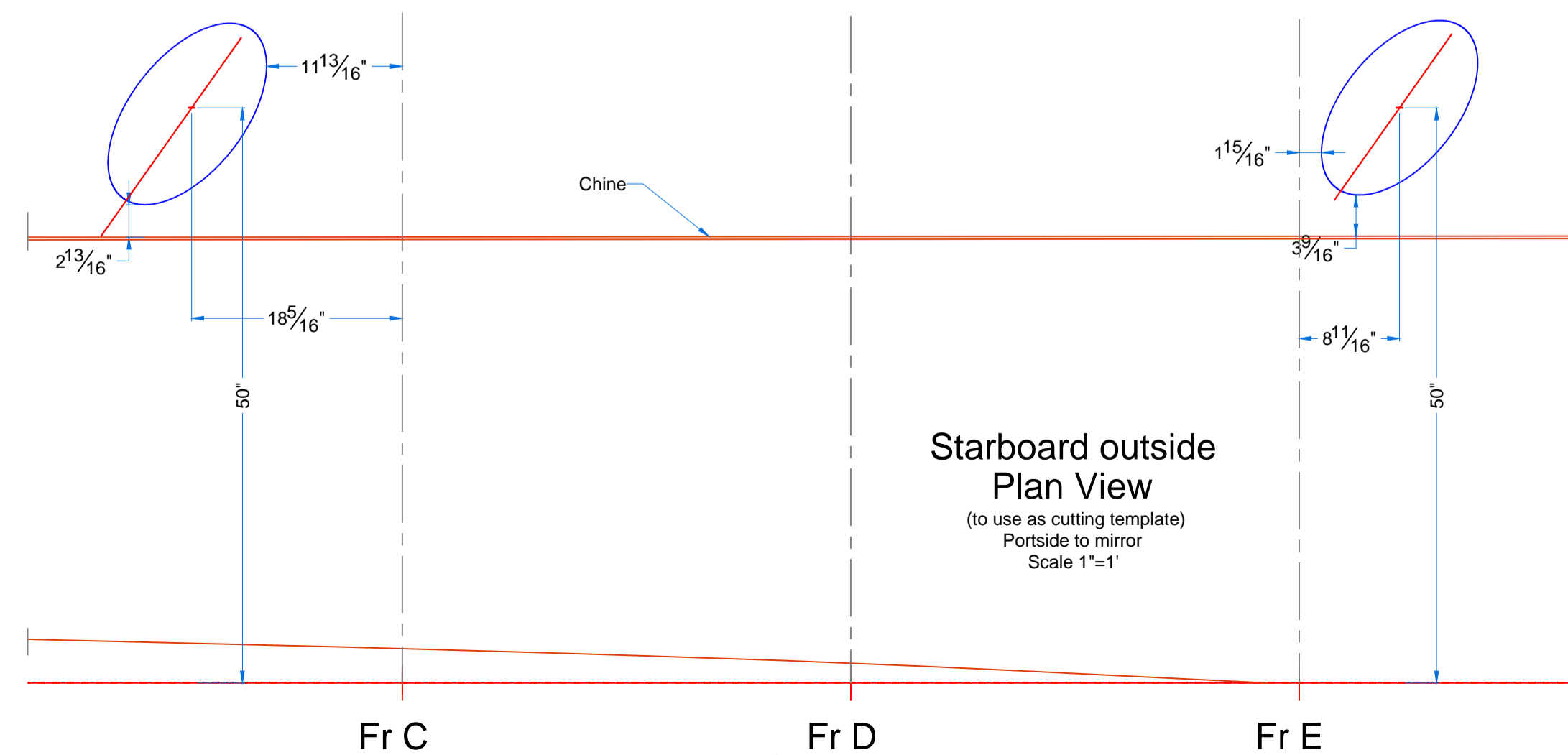

		Teknicraft Design Ltd PO Box 160, Beachlands Auckland, New Zealand Tel: +64 9 536 5070 design@teknicraft.com www.teknicraft.com			
		PROJECT: 24m Catamaran - Rich Passage 2 & 3 TITLE: 3D Views and spigot cutting template			
DRAWING No:	REV:	SCALE:	PLOT SIZE:	USCG	Hull Number:
T24F181-250-003	A	1"=1'	A1	TBD	TD24-53AA TD24-54AA
APPROVAL STATUS:	USCG	TEKNICRAFT:	<small>Unless otherwise stated: • All dimensions in inches • General tolerance ± 1/16" & ± 1 degree</small>		
	Sistership	Checked	Rev. A		
CONFIDENTIAL PROPRIETARY INFORMATION <small>THIS DOCUMENT IS PROPRIETARY! NO DATA OR DESIGN SHALL BE COPIED, REPRODUCED, DISCLOSED OR SUBMITTED TO ANY THIRD PARTY, OR USED FOR CONSTRUCTION OR MANUFACTURE WHOLE OR IN PART, OF ANY PRODUCT WITHOUT PRIOR APPROVAL AND WRITTEN CONSENT FROM TEKNICRAFT DESIGN LTD, NEW ZEALAND</small>					

A	22 Nov 18	Lower brackets added	CL	NDW
-	04 Sep 18	Issued for Construction	CL	NDW
Rev	Date	Description	Init.	Checked